

# Service Manual

Dolby NR-Equipped  
Stereo Double Cassette Deck

Cassette Deck  
**RS-TR373**



**Colour**

(K) ... Black Type



**AR-1 MECHANISM SERIES**

**Area**

Suffix for Model No.	Area	Colour
(P)	U.S.A.	(K)
(PC)	Canada.	
(E)	Europe.	
(EB)	Great Britain.	
(EG)	Germany and Italy.	
(GC)	Asia, Latin, America, Middle Near East and Africa.	
(GN)	Oceania.	

\* Dolby noise reduction and HX Pro headroom extension manufactured under license from Dolby Laboratories Licensing Corporation. HX Pro originated by Bang and Olufsen. "DOLBY", the double-D symbol and "HX PRO" are trademarks of Dolby Laboratories Licensing Corporation.

## SPECIFICATIONS

### ■ CASSETTE DECK SECTION

<b>Deck system</b>	Stereo cassette deck
<b>Track system</b>	4-track, 2-channel
<b>Recording system</b>	AC bias
<b>Bias frequency</b>	80kHz
<b>Erasing system</b>	AC erase
<b>Heads</b>	
<b>DECK 1</b>	Playback head (Permalloy) × 1
<b>DECK 2</b>	Recording/Playback head (Permalloy) × 1 Erasing head (Double-gap ferrite) × 1
<b>Motors</b>	
<b>DECK 1</b>	Capstan drive (DC servo motor) × 1 Reel table drive (DC motor) × 1
<b>DECK 2</b>	Capstan drive (DC servo motor) × 1 Reel table drive (DC motor) × 1
<b>Tape speed</b>	4.8cm/sec. (1-7/8ips)
<b>Wow and flutter</b>	0.1% (WRMS)
<b>For (E, EB, EG, GC, GN) areas</b>	±0.2% (DIN)
<b>Fast forward and rewind times</b>	Approx. 95 seconds with C-60 cassette tape
<b>Frequency response (Dolby NR off)</b>	
<b>NORMAL</b>	40Hz – 15kHz ±3dB
<b>For (P, PC) areas</b>	20Hz – 17kHz
<b>For others</b>	20Hz – 16kHz (DIN)
<b>CrO<sub>2</sub></b>	40Hz – 15kHz ±3dB
<b>For (P, PC) areas</b>	20Hz – 17kHz
<b>For others</b>	20Hz – 16kHz (DIN)

<b>METAL</b>	40Hz – 16kHz ±3dB
<b>For (P, PC) areas</b>	20Hz – 18kHz
<b>For others</b>	20Hz – 17kHz (DIN)
<b>S/N</b> (Signal level = max recording level, CrO <sub>2</sub> type tape)	
<b>NR off</b>	56dB (A weighted)
<b>Dolby B NR on</b>	66dB (A weighted)
<b>Dolby C NR on</b>	74dB (A weighted)
<b>Input sensitivity and impedance</b>	
<b>REC (IN)</b>	100mV/47kΩ
<b>Output voltage and impedance</b>	
<b>PLAY (OUT)</b>	500mV/500Ω

### ■ GENERAL

<b>Power consumption</b>	24W
<b>Power supply</b>	
<b>For (P, PC) areas</b>	AC 60Hz, 120V
<b>For (GC) area</b>	AC 50/60Hz, 110V/127V/220V/240V
<b>For others</b>	AC 50/60Hz, 230V – 240V
<b>Dimensions (W × H × D)</b>	430 × 136 × 285mm (16-15/16" × 5-5/16" × 11-7/32")
<b>Weight</b>	4.4kg (9.7lb.)

**Note:**

Design and specifications are subject to change without notice. Weight and dimensions are approximate.

## CONTENTS

	Page		Page
SAFETY PRECAUTION .....	2	WIRING CONNECTION DIAGRAM.....	25
CONNECTIONS .....	3	TROUBLESHOOTING GUIDE .....	26~31
CAUTION FOR AC MAINS LEAD .....	4	TERMINAL FUNCTION OF IC .....	32~34
FRONT PANEL CONTROLS.....	5	PRINTED CIRCUIT BOARDS .....	35~38
PLAYBACK.....	6, 7	SCHEMATIC DIAGRAM .....	39~46
RECORDING .....	8, 9	BLOCK DIAGRAM.....	47~49
ACCESSORIES .....	9	TERMINAL GUIDE OF IC'S, TRANSISTORS AND DIODES .....	50
TO MAKE A SILENT INTERVAL .....	10	PACKAGING .....	50
TO ERASE RECORDED SOUND.....	10	CABINET PARTS LOCATION .....	51, 52
SELF-DIAGNOSTIC .....	11	REPLACEMENT PARTS LIST .....	53, 54
DISASSEMBLY INSTRUCTIONS.....	12~18	MECHANISM PARTS LOCATION.....	55, 56
WRITING TO EEPROM.....	19~21	REPLACEMENT PARTS LIST .....	57, 58
MEASUREMENTS AND ADJUSTMENTS .....	22~24	RESISTORS AND CAPACITORS .....	59, 60

## SAFETY PRECAUTION (This "safety precaution" is applied only in U.S.A.)

1. Before servicing, unplug the power cord to prevent an electric shock.
2. When replacing parts, use only manufacturer's recommended components for safety.
3. Check the condition of the power cord. Replace if wear or damage is evident.
4. After servicing, be sure to restore the lead dress, insulation barriers, insulation papers, shields, etc.
5. Before returning the serviced equipment to the customer, be sure to make the following insulation resistance test to prevent the customer from being exposed to a shock hazard.

### INSULATION RESISTANCE TEST

1. Unplug the power cord and short the two prongs of the plug with a jumper wire.
2. Turn on the power switch.
3. Measure the resistance value with ohmmeter between the jumpered AC plug and each exposed metal cabinet part, such as screwheads antenna, control shafts, handle brackets, etc. Equipment with antenna terminals should read between 3M $\Omega$  and 5.2M $\Omega$  to all exposed parts (Fig. A). Equipment without antenna terminals should read approximately infinity to all exposed parts (Fig. B).

**Note:** Some exposed parts may be isolated from the chassis by design. These will read infinity.

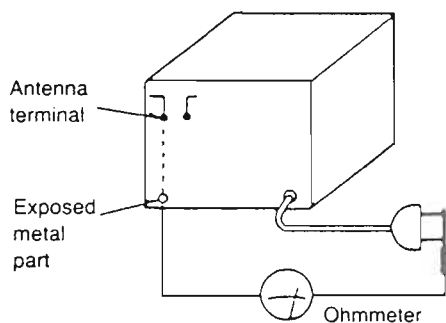

(Fig. A)

Resistance=3 M $\Omega$ -5.2 M $\Omega$

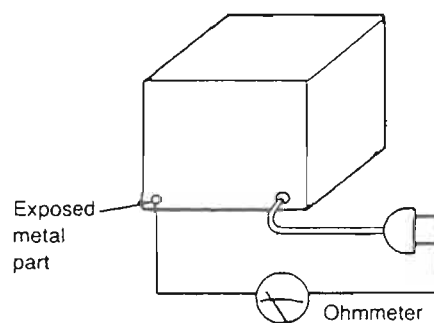

(Fig. B)

Resistance=Approx.  $\infty$

4. If the measurement is outside the specified limits, there is a possibility of a shock hazard. The equipment should be repaired and rechecked before it is returned to the customer.

# CONNECTIONS

## • For (P, PC) areas

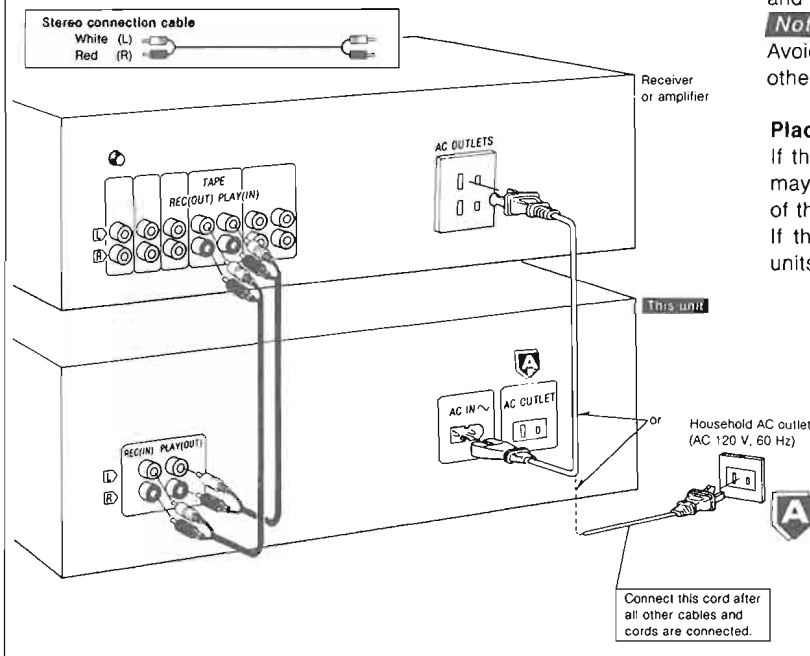

Before making connections, make sure that the power to this unit and all other system components is turned off first.

**Note**

Avoid letting the cables touch each other as much as possible, otherwise noise will be generated.

**Placement hints**

If this unit is placed near a receiver or a tuner, a "hum" noise may be heard during tape playback, recording, or AM reception of the receiver or the tuner.

If this occurs, leave as much space as possible between the units, or place them where there is the least amount of "hum"

**A "AC OUTLET" (UNSWITCHED)**

Power is always available, regardless of the unit's power switch setting.

Audio equipment rated up to 100 W can be connected.

## • For others

Before making connections, make sure that the power to this unit and all other system components is turned off

**Note**

- Avoid letting the cables touch each other as much as possible, otherwise noise will be generated.
- Although the figure below shows the AC power supply cord being connected to a household AC outlet, if the amplifier (or receiver) is equipped with an AC outlet, connect the cord to that outlet.

**Placement hints**

If this unit is placed near a receiver or a tuner, a "hum" noise may be heard during tape playback, recording, or AM reception of the receiver or the tuner.

If this occurs, leave as much space as possible between the units, or place them where there is the least amount of "hum".

**For (EB) area only**

**BE SURE TO READ THE CAUTION FOR AC POWER SUPPLY CORD ON PAGE 3 BEFORE THE FOLLOWING CONNECTIONS.**

**For (GC) area only**

Set the voltage selector to the voltage setting for the area in which the unit will be used.

[Use a minus (-) screwdriver]

**Note**

If the power supply in your area is 117 V or 120 V, set to the "127 V" position.

Note that this unit will be seriously damaged if this setting is not made correctly.

If the power plug will not fit your socket, use the power plug adaptor (included).

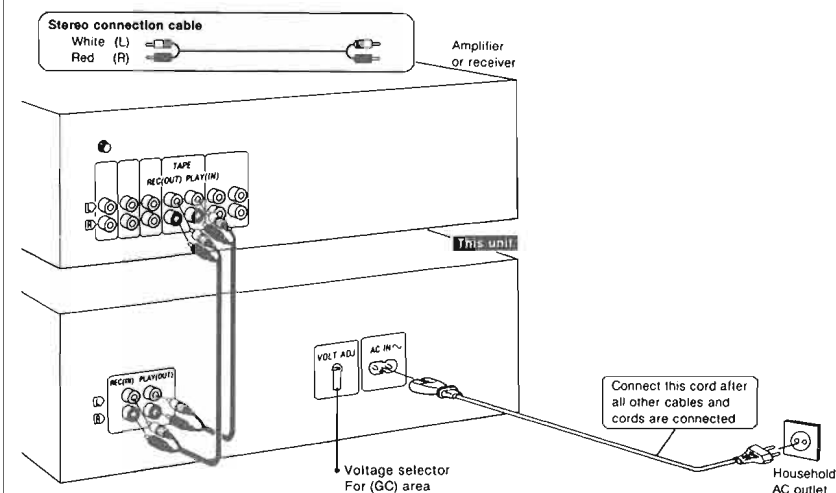
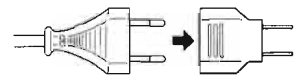

**For (E, EB, EG, GC) areas only**  
**Insertion of Connector**

Even when the connector is perfectly inserted, depending on the type of inlet used, the front part of the connector may jut out as shown in the drawing.

However there is no problem using the unit.

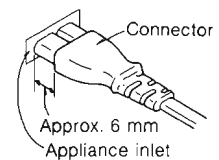

## ■ CAUTION FOR AC MAINS LEAD



### For (EB) area only

For your safety, please read the following text carefully.

This appliance is supplied with a moulded three pin mains plug for your safety and convenience.

A 5-ampere fuse is fitted in this plug.

Should the fuse need to be replaced please ensure that the replacement fuse has a rating of 5-ampere and that it is approved by ASTA or BSI to BS1362.

Check for the ASTA mark  or the BSI mark  on the body of the fuse.

If the plug contains a removable fuse cover you must ensure that it is refitted when the fuse is replaced.

If you lose the fuse cover the plug must not be used until a replacement cover is obtained.

A replacement fuse cover can be purchased from your local dealer.

### CAUTION!

IF THE FITTED MOULDED PLUG IS UNSUITABLE FOR THE SOCKET OUTLET IN YOUR HOME THEN THE FUSE SHOULD BE REMOVED AND THE PLUG CUT OFF AND DISPOSED OF SAFELY.

THERE IS A DANGER OF SEVERE ELECTRICAL SHOCK IF THE CUT OFF PLUG IS INSERTED INTO ANY 13-AMPERE SOCKET.

If a new plug is to be fitted please observe the wiring code as shown below.

If in any doubt please consult a qualified electrician.

### IMPORTANT

The wires in this mains lead are coloured in accordance with the following code:

Blue: Neutral

Brown: Live

As the colours of the wires in the mains lead of this appliance may not correspond with the coloured markings identifying the terminals in your plug, proceed as follows:

The wire which is coloured BLUE must be connected to the terminal in the plug which is marked with the letter N or coloured BLACK.

The wire which is coloured BROWN must be connected to the terminal in the plug which is marked with the letter L or coloured RED.

Under no circumstances should either of these wires be connected to the earth terminal of the three pin plug, marked with the letter E or the Earth Symbol .

### Before use

Remove the connector cover as follows.

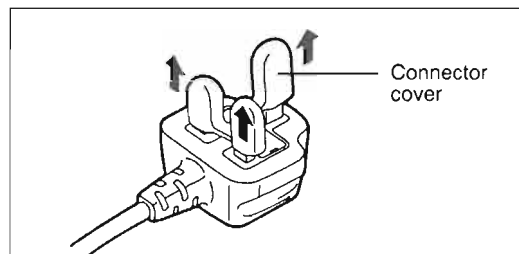

### How to replace the fuse

1. Remove the fuse cover with a screwdriver.

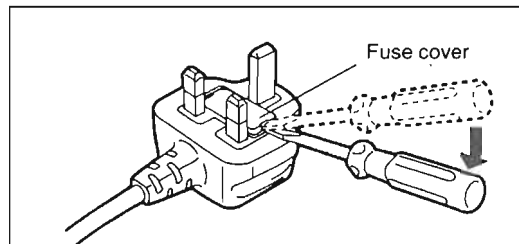



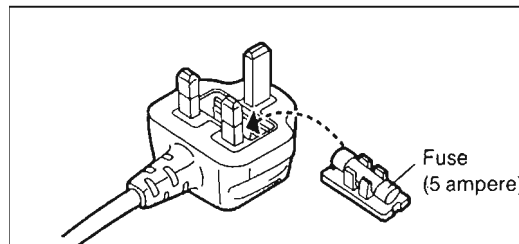



2. Replace the fuse and attach the fuse cover.

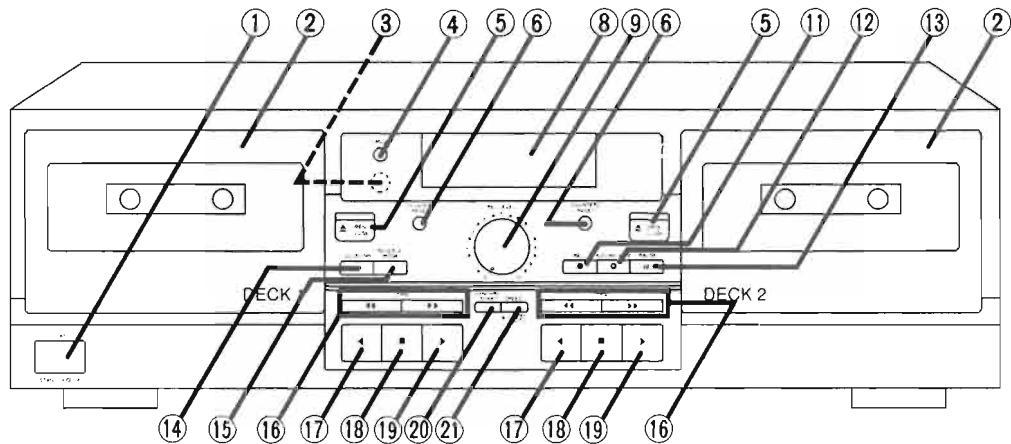







## FRONT PANEL CONTROLS

When any of the numbers indicated below is repeated more than once (for example, ②), the number indicated on the left is the control for Deck 1 and that indicated on the right is for Deck 2.



No.	Name
①	<b>Power “STANDBY  ON” switch (POWER, STANDBY  ON)</b> Press to switch the unit from on to standby mode or vice versa. In standby mode, the unit is still consuming a small amount of power
②	<b>Cassette holder</b>
③	<b>Remote control signal receptor</b>
④	<b>“STANDBY” indicator (STANDBY)</b> When the unit is connected to the AC mains supply, this indicator lights up in standby mode and goes out when the unit is turned on. <b>For (E, EB, EG, GC, GN) areas</b>
⑤	<b>Open/close button (  OPEN/CLOSE)</b>
⑥	<b>Counter reset button (COUNTER RESET)</b>
⑧	<b>Display</b>
⑨	<b>Recording-level control (REC LEVEL)</b>
⑪	<b>Record button (  REC)</b>
⑫	<b>Automatic-record-muting button (  AUTO REC MUTE)</b>

No.	Name
⑬	<b>Pause button (  PAUSE)</b>
⑭	<b>Dolby noise-reduction button (DOLBY NR)</b>
⑮	<b>Reverse-mode select button (REVERSE MODE)</b>
⑯	<b>Rewind/fast-forward search buttons (   TPS)</b>
⑰	<b>Reverse-side playback button (  )</b>
⑱	<b>Stop button (  )</b>
⑲	<b>Forward-side playback button (  )</b>
⑳	<b>Synchro-start button (SYNCHRO START)</b>
㉑	<b>Tape-to-tape recording-speed button (SPEED)</b>

# PLAYBACK

Either normal, CrO<sub>2</sub> or metal type cassettes can be used.

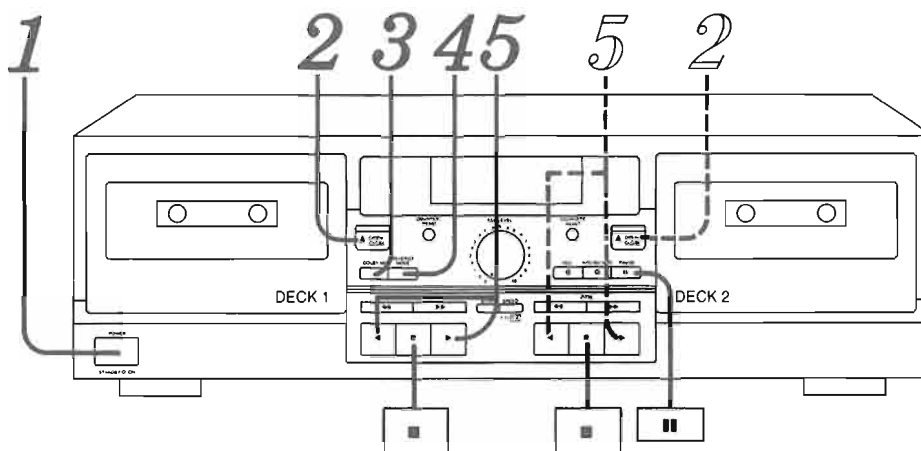

The procedures described below are an example of playback on Deck 1.

**1** **POWER** **Press POWER.**  
(The unit will switch on.)

**2** **OPEN/CLOSE** **Press OPEN/CLOSE, and then insert the cassette tape.**  
Press again to close the cassette holder.

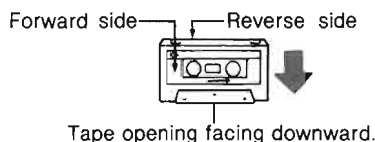

When the cassette holder is open, pressing ◀▶, ▶▶ or ▶▶▶ will close the holder and begin the desired function.

**3** **DOLBY NR** **Press DOLBY NR to select the appropriate noise-reduction system.**

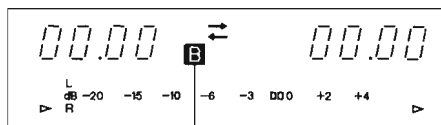

Each time the button is pressed, the indicators will change in the order: **B** → **C** → off.

Select the same type as that used for recording. When playing back a tape which was not recorded using a Dolby NR system, press so that the indicators go off.

**4** **REVERSE MODE** **Press REVERSE MODE to select the appropriate reverse mode.**

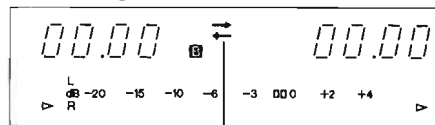

Each time the button is pressed, the indicator will change in the order: .

- : One side only.
  - : Both sides repeatedly (up to 8 times).
  - : Both sides, once only.
- (Refer to page 7.)

**5** **▶ or ◀** **Press ▶ or ◀.**  
(Playback will begin.)  
▶ : To begin from the forward side.  
◀ : To begin from the reverse side.

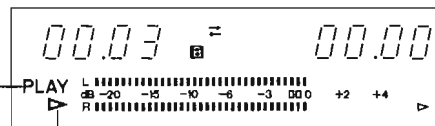

Illuminates Indicates the side being played.

To play back on Deck 2, in steps 2 and 5 above, press the buttons ( 2 and 5 ) for Deck 2.

## To temporarily stop playback

(Deck 2 only)

**Press ||.**  
The "PLAY" indicator will flash.

Press once again to resume playback.

## To stop playback

**Press ■.**

## Reverse function

The reverse function on this unit has three modes (→, ↺, ↻). Read the descriptions below and select the mode as desired.

Mode	Tape travel
→ ←	Only one side of the tape (either the forward side or the reverse side) will be played, and operation will automatically stop when playback has been completed.
↺	Both sides of the tape will be played repeatedly eight times, and then operation will automatically stop. (If playback is begun from the reverse side, the forward side will be played seven times.)
↻	<b>When there is a tape in only one of the decks</b> Both sides of the tape will be played once, and then operation will automatically stop. (If playback is begun from the reverse side, the forward side will not be played.) <b>When there is a tape in each of the decks</b> The forward and reverse sides of the tape in Deck 1 will be played, followed by the forward and reverse sides of the tape in Deck 2, and after this operation is repeated eight times, operation will automatically stop. (If playback is begun from Deck 2, the tape in Deck 1 will be played seven times.)

## About the automatic-tape-select function

This unit is equipped with the automatic-tape-select feature; it automatically detects the type of tape being used, and then makes the suitable adjustments of the bias and equalization accordingly.

## About the remote control function

When connecting a Technics amplifier with the remote control transmitter to this unit, you can operate this unit using a remote control transmitter of the amplifier.

(See the operating instructions of the amplifier.)

During operation from the remote control, the "R.C." indicator will light up.

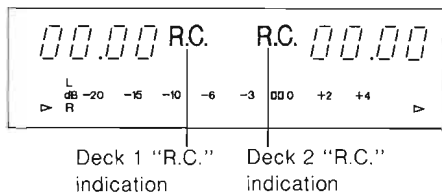

## About the Dolby noise-reduction system

The Dolby noise-reduction system is designed to effectively reduce the annoying high-frequency "hissing" noise typical of cassette tapes. During recording, the system functions to increase the high-frequency sound level, the sound, and then, during playback, that same portion is weakened to bring it back to the previous level.

This unit includes two types of Dolby noise-reduction systems, the Dolby B NR-type and C NR-type.

### Dolby B-type noise-reduction

Noise is reduced to about one-third.

Use this system when playing back tapes recorded by the Dolby B noise-reduction system, such as prerecorded music tapes, etc.

### Dolby C-type noise-reduction

Noise is reduced to about one-tenth.

Use this system for the recording and playback of sound sources that have a wide dynamic range and good tone quality, such as FM broadcasts of live performances, etc., and for playing back such tapes.

## About the Dolby HX-Pro headroom extension system

By functioning to improve the maximum output level of the tape's high-frequency range, this system permits recordings without a reduction in the level of the sound source's high-frequency range. In addition, by using the system in parallel with this unit's noise-reduction system, recording and playback with a greatly extended dynamic range is possible.

Dolby noise reduction and HX Pro headroom extension manufactured under license from Dolby Laboratories Licensing Corporation. HX Pro originated by Bang & Olufsen.

"DOLBY", the double-D symbol  and "HX PRO" are trademarks of Dolby Laboratories Licensing Corporation.

# RECORDING (Deck 2 only)

Either normal, CrO<sub>2</sub> or metal type cassettes can be used.

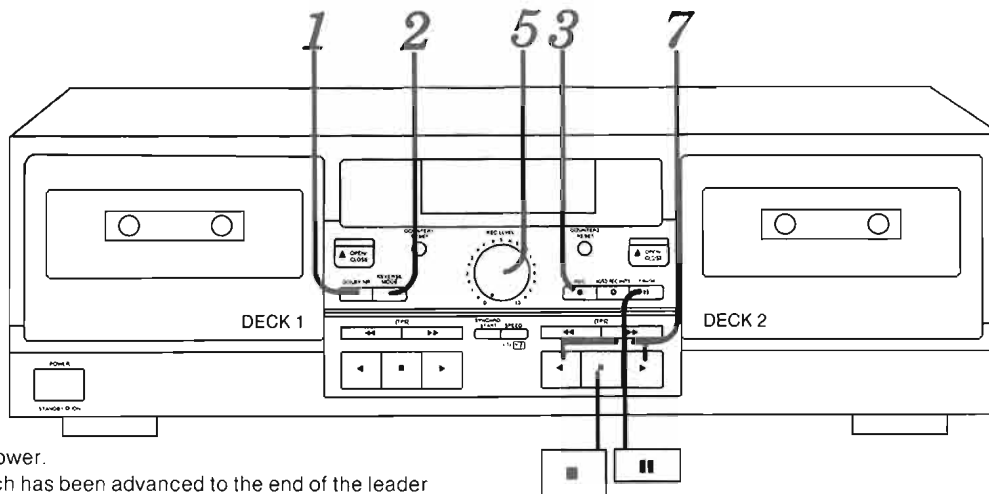

### Preparation

1. Switch on the power.
2. Load a tape which has been advanced to the end of the leader tape (the transparent part at both ends of the tape) into Deck 2.

**1**

DOLBY NR

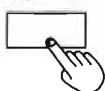

**Press DOLBY NR to select the desired noise-reduction system.** (Refer to the opposite page.)

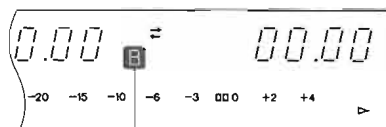

Each time the button is pressed, the indicator will change in the order:  
**B** → **C** → off.

**3**

REC



**Press REC ●.**

(The unit will be in the recording standby mode.)

Illuminates

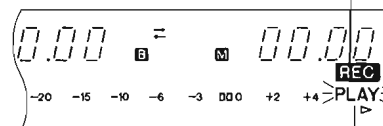

Flashes

**2**

REVERSE MODE

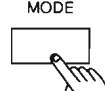

**Press REVERSE MODE to select the desired reverse mode.**

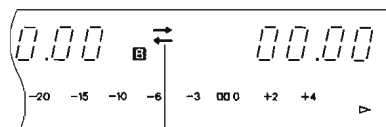

Each time the button is pressed, the indicator will change in the order:

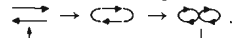

↔ : Only one side will be recorded, and then operation will automatically stop.

↔ ∞ : Both sides (the forward side first, and then the reverse side) will be recorded, and then operation will automatically stop.

**4**

**Play the source in order to adjust the recording sound.**

**5**

REC LEVEL

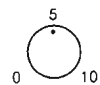

**Use the REC LEVEL control to adjust the recording level.** (Refer to the right side of this page.)

**6**

**Stop play of the source.**



**7**

**Press ◀ or ▶ to begin recording, and play the source to be recorded.**

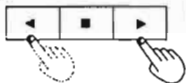

- ▶: To begin recording from the forward side.
- ◀: To begin recording from the reverse side.

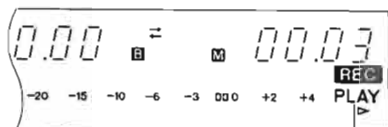

Illuminates

**Note**

When recording on both sides of the tape, be sure to press the ▶ button.

When recording without using the ATC function, step 3 is unnecessary.

**To temporarily stop recording**



**Press ||.**

Press once again to resume recording.

**To stop recording**

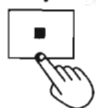

**Press ■.**

**About the selection of the Dolby NR type**

The Dolby NR effect can be obtained by using the same type of Dolby NR during both recording and playback. Refer to the following table when selecting the type (either B or C).

<b>Type B</b>	Use this type when the deck on which the tape will be played back is equipped with only type B Dolby NR.
<b>Type C</b>	Use this type when the deck on which the tape will be played back is equipped with type C Dolby NR. (for example, when this unit is also going to be used to play back the tape.)

(Refer to "About the Dolby noise-reduction system" on page 7.)

**About the recording level adjustment**

If the recording level is too high, there will be distortion in the recorded sounds, and if it is too low, the hiss noise inherent to recording tapes will become noticeable.

In order to make high-quality recordings, use the REC LEVEL control to adjust so that highest values of the input level indicated by the level meter do not exceed the standard recording level (the number indicated in parentheses) for the tape being used.

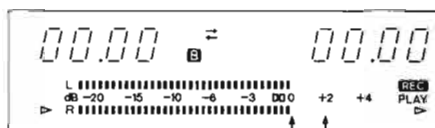

Normal or CrO<sub>2</sub> tape (0)      Metal tape (+2)

**ACCESSORIES**

AC power supply code ..... 1 pc.  
(VJA0733)... (EB)

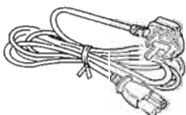

(SJA172)... (P, PC)

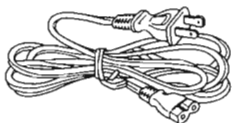

(RJA0036-K)... (GN)

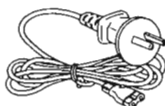

(RJA0019-2K)... (E, EG, GC)

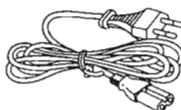

Stereo connection cables ..... 2 pcs.  
(SAJ2249-3)

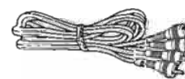

Power plug adaptor..... 1 pc.  
(SJP5213-1) (For GC area only)

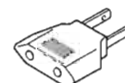

## TO MAKE A SILENT INTERVAL

A silent interval of 4 seconds or more can be provided between tracks. This function is useful for playing back on decks which can skip to the beginning of tracks, and for cutting unwanted sound from commercials.

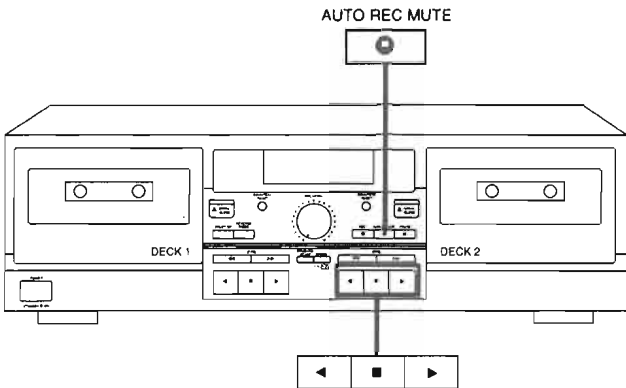

### To make a 4-second silent interval

AUTO REC MUTE



**Press AUTO REC MUTE momentarily while a recording is being made.**

A 4-second silent interval will be recorded, and the unit will automatically be set to the recording standby mode.

### To make a silent interval more than 4 seconds

AUTO REC MUTE



**Press and hold AUTO REC MUTE for the necessary number of seconds while a recording is being made.**

The unit will change to the recording stand-by mode when the button is released.

### To resume recording

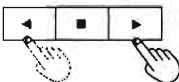

**Press either ◀ or ▶, corresponding to the side of the tape side indicator which is lit.**

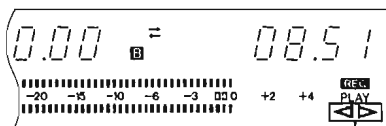

Tape side indicator

## TO ERASE RECORD SOUND

When new recordings are made on a pre-recorded tape, all sounds recorded on that portion of the tape are automatically erased. To erase a tape without making a new recording, follow the steps below.

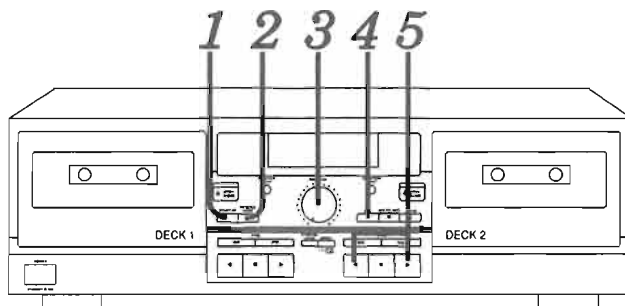

### Preparation

Load the tape to be erased into Deck 2.

1

DOLBY NR

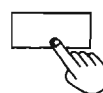

**Press DOLBY NR so that the Dolby NR indicators ("B" and "C") are off.**  
(Refer to page 8.)

2

REVERSE MODE

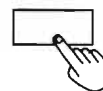

**Press REVERSE MODE to select the desired reverse mode.**

↔ : To erase one side of the tape.  
↔↔, ↔↔ : To erase both sides of the tape.

(Refer to page 8.)

3

REC LEVEL

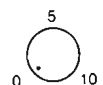

**Set the REC LEVEL control to "0".**

4

REC

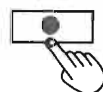

**Press REC.**

(The unit will be in the recording stand-by-mode.)

5

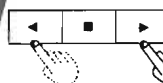

**Press ◀ or ▶ to begin erasing the tape.**

▶ : To erase the forward side of the tape.

◀ : To erase the reverse side of the tape.

### Note

To erase both sides of the tape, be sure to press the ▶ button.

## ■ SELF-DIAGNOSTIC

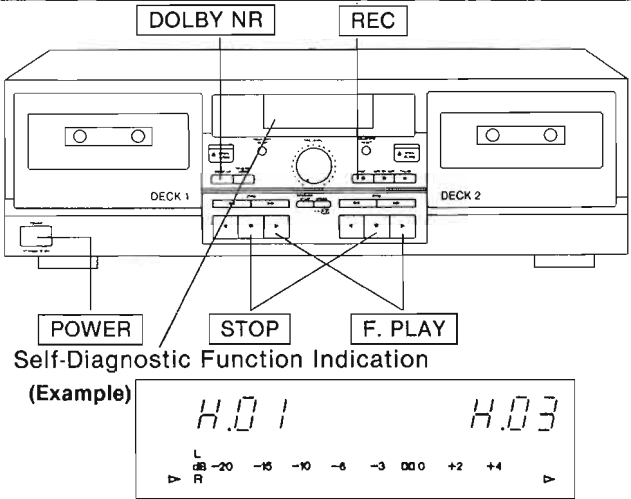
Indicating Procedure	Indicating Position
<p><b>To indicate Self-Diagnostic Function</b></p> <ol style="list-style-type: none"> <li>1. Check both Deck 1 and 2 are empty (no cassette tape), then turn on the power.</li> <li>2. Press and hold the DOLBY (NR) button (for more than 3 seconds), and also press the Deck 2 STOP (■) button for about 2 seconds until the level meter changes from constantly lit to blinking.</li> <li>3. Insert a normal tape for Deck 2, either A or B side of which has the erase preventing piece folded. Then close the cassette holder.</li> <li>4. Press the Deck 2 F. PLAY (▶) button and play the tape for more than 1 second, then press the STOP (■) button.</li> <li>5. Insert a normal blank cassette tape for DECK 2, both A and B sides of which have the erase preventing pieces respectively, and close the cassette holder.</li> <li>6. Press the REC (●) button. This automatically makes Deck 2 perform the following operations.</li> </ol>	 <p>Self-Diagnostic Function Indication (Example)</p>
<p>Record an eight second portion with no sound. ⇒ Record a 20 second portion off 400Hz test signal.</p>	
	<p>TPS-REVIEW search mode ← Stop the unit</p>
<p>(NOTE: The tape has to be taken up by playback for about 1 minute.)</p>	
<ol style="list-style-type: none"> <li>7. Insert a normal tape for Deck 1, either A or B side of which has the erase preventing piece folded. Then close the cassette holder.</li> <li>8. Press the Deck 1 FF (▶▶) button. This automatically makes Deck 1 Perform the following operations.</li> </ol>	
<p>FF mode (approx. 2 second) ⇒ REW mode (approx. 2 second) ⇒ Stop the unit</p>	
<ol style="list-style-type: none"> <li>9. Press the Deck 1 STOP (■) button to display the self-diagnostic results for Deck 1, and press the Deck 2 STOP (■) button to display the results for Deck 2. When a fault occurs in Deck 1 and/or Deck 2, the FL display indicates the results of self-diagnostic tests. For multiple faults, the indication changes each time the STOP (■) button is pressed.</li> </ol>	
<ol style="list-style-type: none"> <li>10. If there is no fault, the counter display remains unchanged when the STOP (■) button is pressed.</li> </ol>	
<p><b>To resume Ordinary Indication</b></p>	
<p>To return the display to normal mode, switch the power off and then back on again.</p>	
<p>To have the indication appear again, take the above-stated steps 1, 2 and 9.</p>	
<p><b>NOTE:</b> The contents of the self-diagnostic mode are stored in memory. To clear the memory, press the STOP (■) button on Deck 2 for more than 6 seconds, until "CL" appears in the FL display.</p>	

### Indication Text

Symbol	Trouble	Remedy
H01	Irregular action of cassette mechanism. (Example) Pressing the FWD PLAY button results in REW PLAY action.	The cassette mechanism mode switch and plunger are defective. (Check and replace them.)
H02	No recording can be made, or the unit is placed in the recording mode though the erase preventing piece has been broken.	The erase preventing switch contacts improperly, or there is a shortcircuit. (Check and replace the switch.)
H03	Pressing the PLAY (▶) button fails to play the tape. Pressing the PLAY (▶) button causes the motor to rotate though no cassette tape is in.	The cassette half detect switch contacts improperly, or there is a shortcircuit. (Check and replace the switch.)
H04	The cassette holder will not open or close when the OPEN/CLOSE (▲) button is pressed.	The cassette holder open/close detect switch contacts improperly, or there is a shortcircuit. (Check and replace the switch.)
H05	Pressing the OPEN/CLOSE (▲) button causes the cassette holder to open after it has closed, and vice versa.	
H06	No treble is produced when a normal tape is played or recorded.	The auto tape select (CrO <sub>2</sub> ) switch contacts improperly, or there is a shortcircuit. (Check and replace the switch.)
H07	Excessive treble is produced when a CrO <sub>2</sub> /Metal tape is played, or the recorded treble is distorted and at a low level.	The automatic tape select (Metal) switch contacts improperly, or there is a shortcircuit. (Check and replace the switch.)
F01	When the PLAY (▶) button is pressed, the tape runs a little and stops soon.	The hall IC is defective and, as the result, reel pulse is out of order. (Check and replace the IC.)
F02	TPS dose not operate.	The playback IC is defective. (Check and replace the IC.)

## DISASSEMBLY INSTRUCTIONS

### "ATTENTION SERVICER"

Some chassis components may have sharp edges. Be careful when disassembling and servicing.

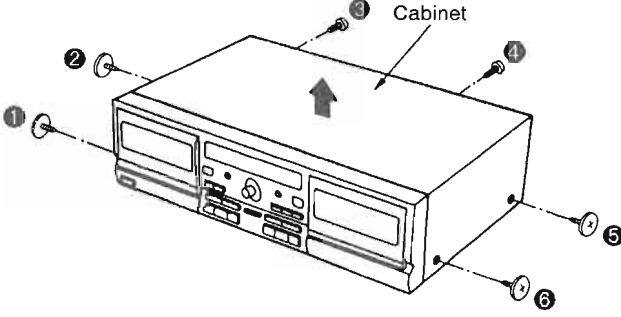
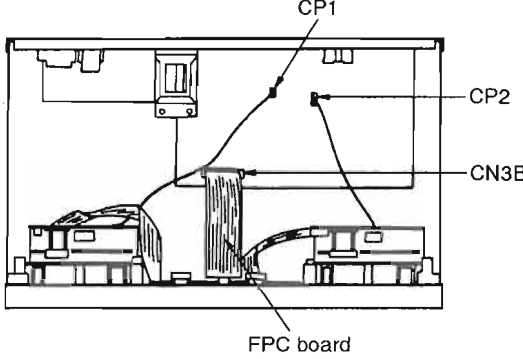
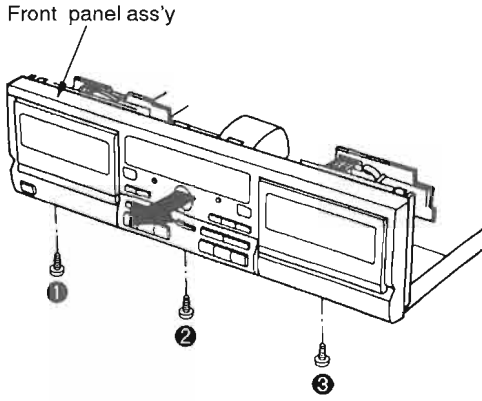
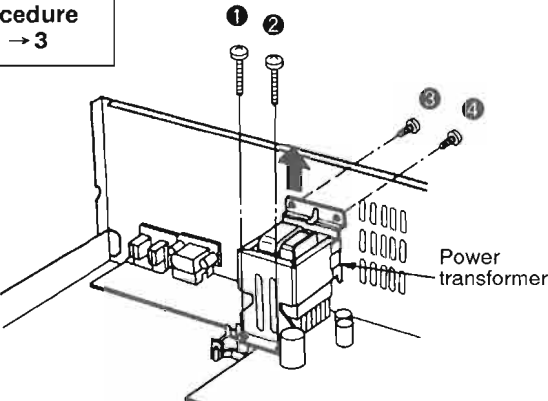
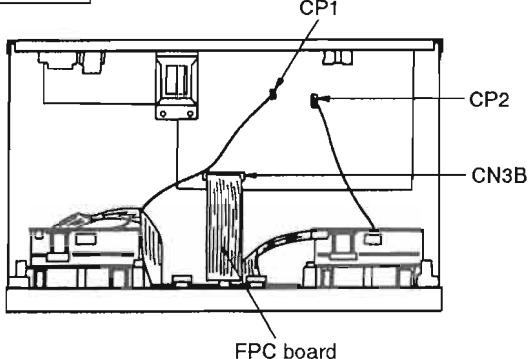
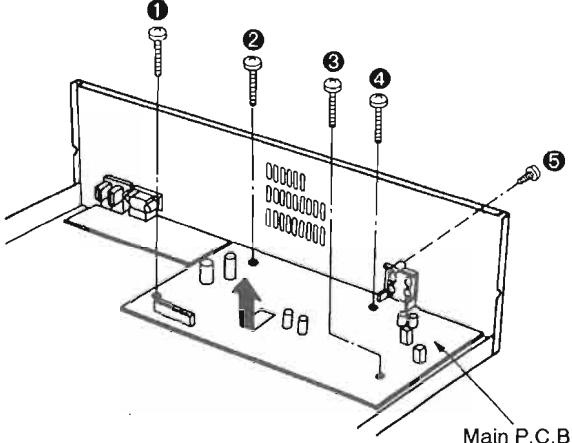
<b>Ref.No.</b> 1	<b>Removal of the cabinet</b>	<b>Ref.No.</b> 2	<b>Removal of the front panel ass'y</b>
<b>Procedure</b> 1		<b>Procedure</b> 1→2	
<ol style="list-style-type: none"> <li>1. Remove the 6 screws (① ~ ⑥).</li> <li>2. Remove the cabinet in the direction of arrow.</li> </ol>		<ol style="list-style-type: none"> <li>1. Remove the 2 connectors (CP1, CP2).</li> <li>2. Pull out the FPC board from connector (CN3B).</li> </ol>	
<b>Ref.No.</b> 3	<b>Removal of the power transformer</b>		
<b>Procedure</b> 1→3			
<ol style="list-style-type: none"> <li>1. Remove the 4 screws (① ~ ④).</li> <li>2. Pull the front power transformer in the direction of arrow.</li> </ol>		<ol style="list-style-type: none"> <li>3. Remove the 3 screws (① ~ ③).</li> <li>4. Remove the front panel ass'y in the direction of arrow.</li> </ol>	
<b>Ref.No.</b> 4	<b>Removal of the main P.C.B.</b>		
<b>Procedure</b> 1→3→4			
<ol style="list-style-type: none"> <li>1. Remove the 2 connectors (CP1, CP2).</li> <li>2. Pull out the FPC board from connector (CN3B).</li> </ol>		<ol style="list-style-type: none"> <li>3. Remove the 5 screws (① ~ ⑤).</li> <li>4. Remove the main P.C.B. in the direction of arrow.</li> </ol>	

<b>Ref.No.</b> 5	<b>Removal of the loading cassette mechanism units(DECK 1, DECK 2)</b>
<b>Procedure</b> 1 → 2 → 5	

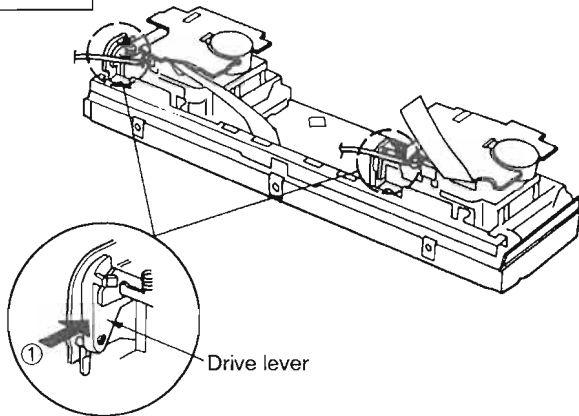

1. Push the drive lever in the direction of arrow ①, and open the cassette holder ass'y.

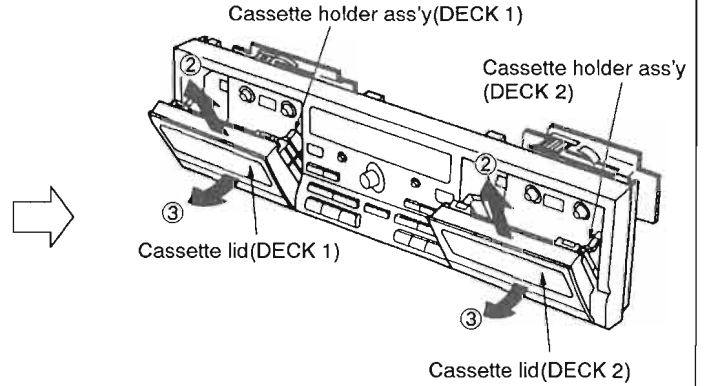

2. Lift the cassette lid in the direction of arrow ②, and remove it in the direction of arrow ③.

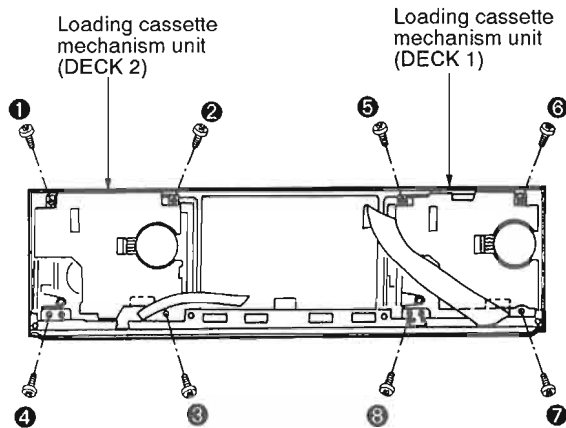

5. Remove the 8 screws(① ~ ⑧).

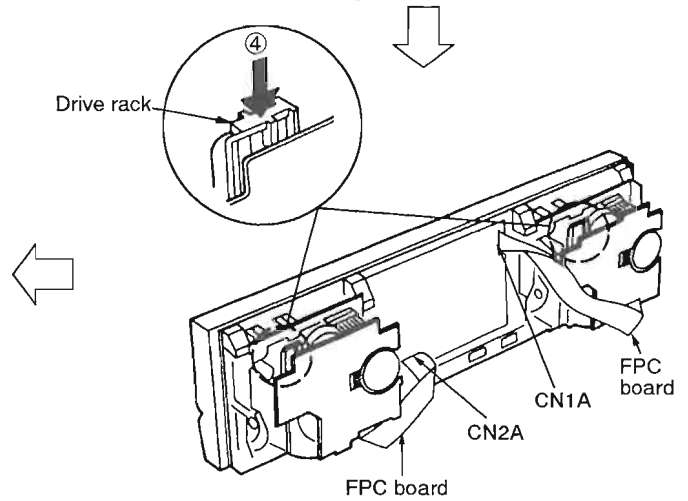

3. Push the drive rack in the direction of arrow ④, and close the cassette holder ass'y.

4. Pull out the FPC board from connectors(CN1A, CN2A).

<b>Ref.No.</b> 6	<b>Removal of the mechanism angle</b>
<b>Procedure</b> 1 → 2 → 5 → 6	

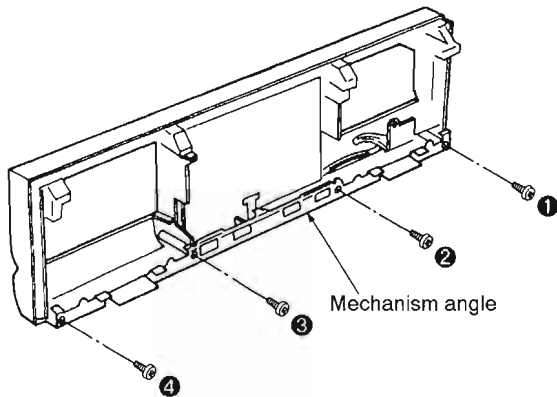

• Remove the 4 screws(① ~ ④).

<b>Ref.No.</b> 7	<b>Removal of the operation P.C.B.</b>
<b>Procedure</b> 1 → 2 → 5 → 6 → 7	

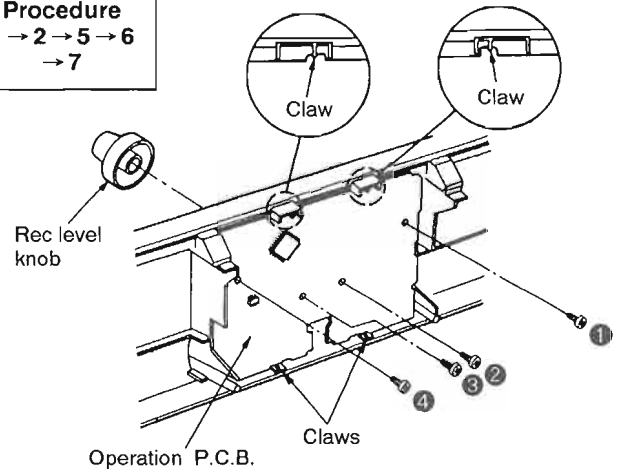

1. Pull out the rec level knob.  
2. Remove the 4 screws(① ~ ④).  
3. Release the 4 claws.

<b>Ref.No.</b> 8	<b>Removal of the power switch P.C.B.</b>
<b>Procedure</b> 1 → 2 → 5 → 6 → 8	
<p>1. Remove the 1 screw (①).</p>	<p>2. Tilt the power switch P.C.B. in the direction of arrow ①, and then remove it in the direction of arrow ②.</p>

<b>Ref.No.</b> 9	<b>Removal of the rear panel</b>
<b>Procedure</b> 1 → 3 → 9	
<p>1. Remove the 6 screws (① ~ ⑥). For [P, PC] areas.          2. Remove the 5 screws (② ~ ⑥). For [E, EB, EG, GC, GN] areas.          3. Remove the rear panel in the direction of arrow.</p>	

<b>Ref.No.</b> 10	<b>Removal of the motor P.C.B. (DECK 1, DECK 2)</b>
<b>Procedure</b> 1 → 2 → 5 → 10	
<p>1. Remove the 2 screws (①, ②).          2. Unsolder the reel motor and capstan motor terminals.          3. Remove the 1 claw and have the P.C.B. rise a little.</p>	

■ The difference types of capstan motor terminal are used for the units. When assembling/reassembling, refer to the Fig. 1 and Fig. 2.

※ Notice for mounting the motor P.C.B.

1. Cut the bent terminal of capstan motor with a nipper.
2. Solder while pressing the part with a ⊖ screwdriver or an equivalent tool.

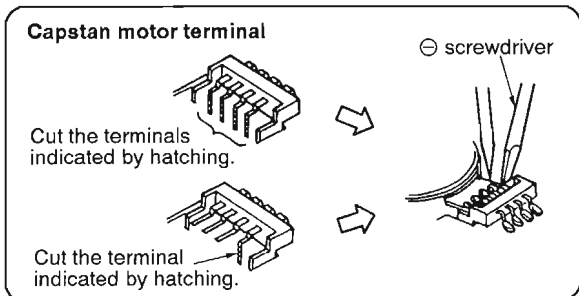

Fig. 2

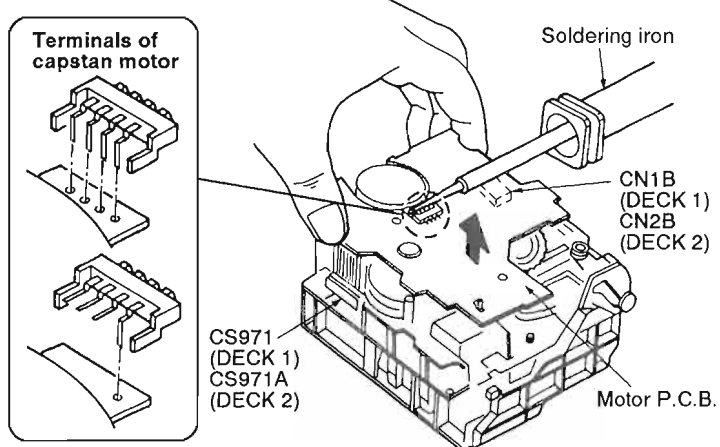

Fig. 1

4. Putting a soldering iron securely on the capstan motor terminal and raising the motor P.C.B. in the direction of arrow, unsolder connected part.

Note) When removing the motor P.C.B., pull out the P.C.B. severely because the connectors (CN1B, CN2B, CS971, CS971A) are connected.

**Ref.No. 11**      **Removal of the power supply P.C.B.**

**Procedure**  
1 → 3 → 9 → 11

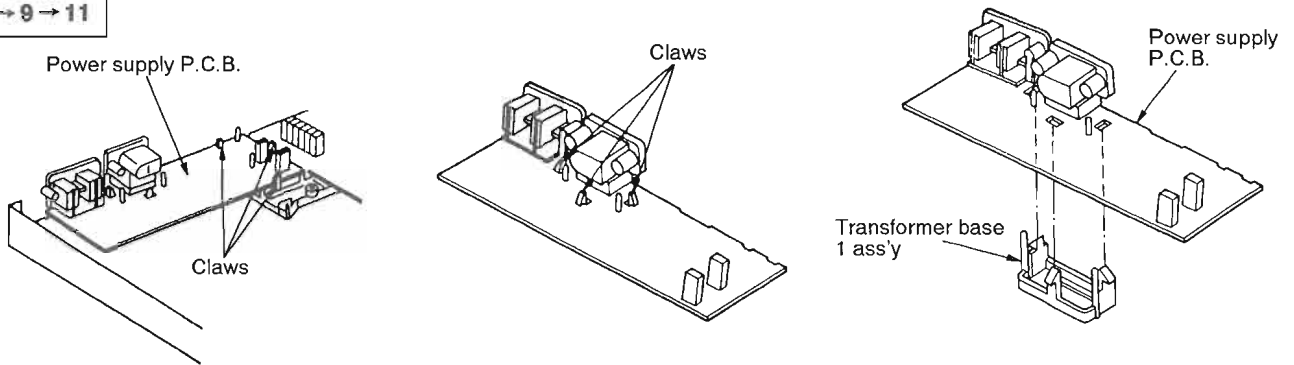

1. Release the 3 claws, and then remove the power supply P.C.B.

2. Release the 3 claws, and then remove the transformer base 1 ass'y.

**Ref.No. 12**      **Removal of the cassette holder ass'y (DECK 1, DECK 2)**

**Procedure**  
1 → 2 → 5 → 12

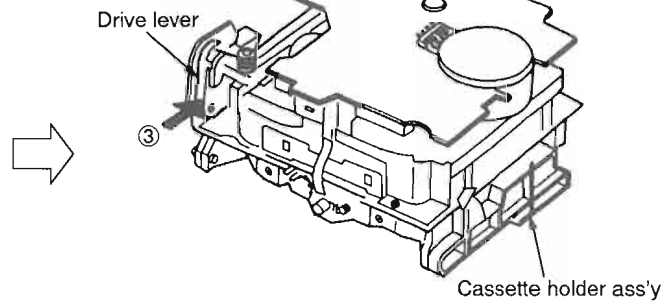
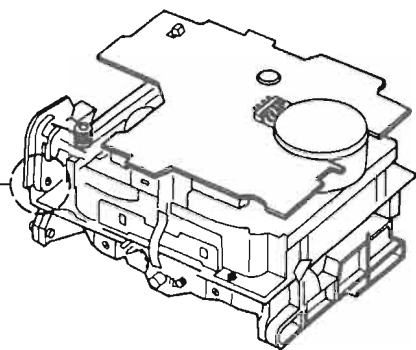
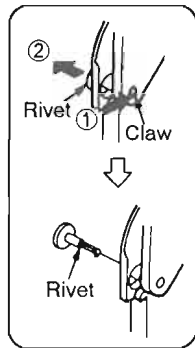

1. Pull out the rivet in the direction of arrow ②, while pressing the claw in the direction of arrow ①.

2. Push the drive lever in the direction of arrow ③, and open the cassette holder ass'y.

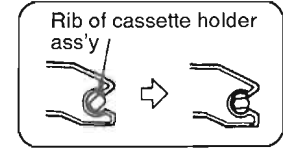
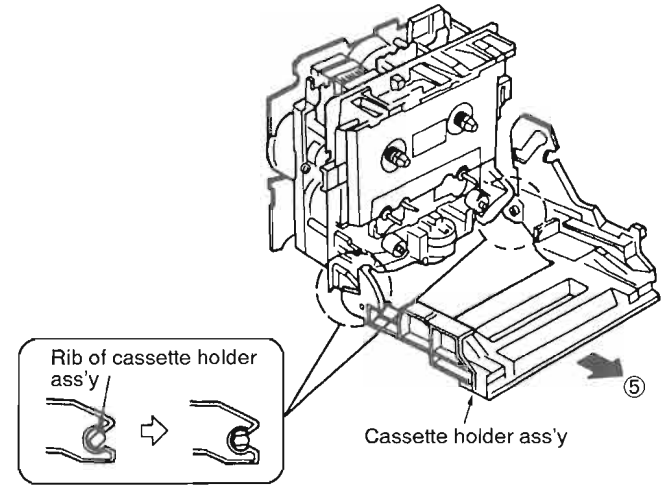
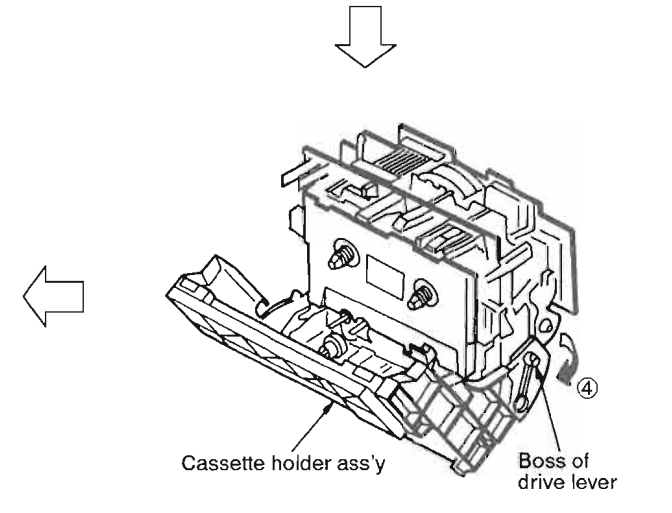
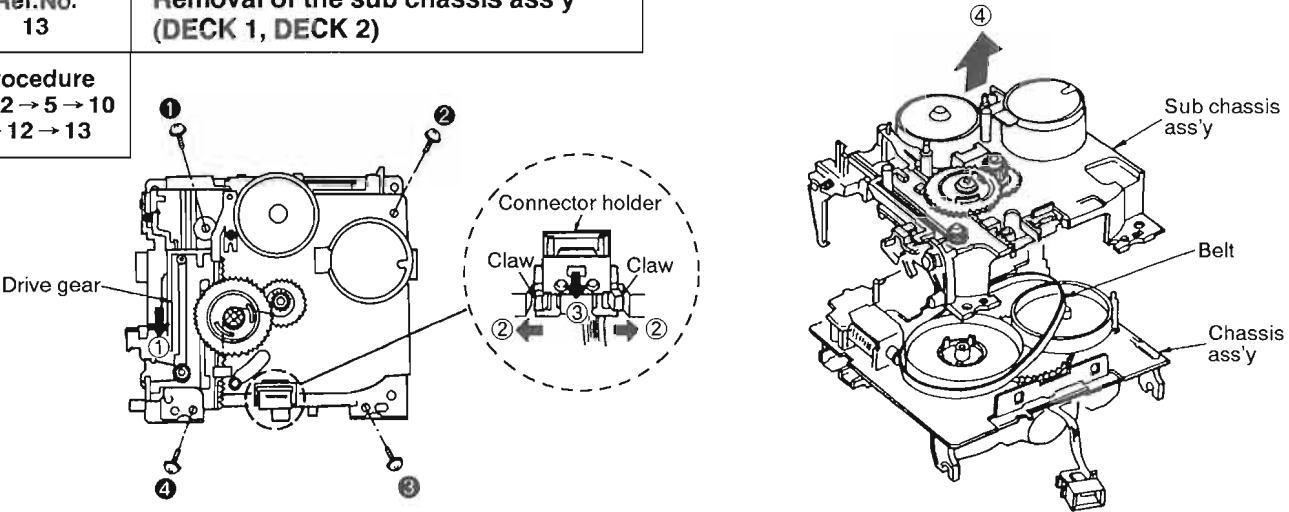
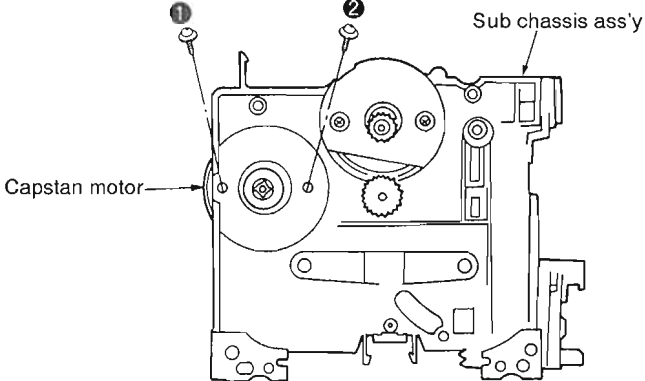

Fig. 1



4. Open the cassette holder ass'y so that the rib of the cassette holder ass'y is located to the position as shown in Fig.1, and then pull out it in the direction of arrow ⑤.

3. Operate the cassette holder ass'y in the direction of arrow ④, and then remove it from the boss of drive lever.

<b>Ref.No.</b> 13	<b>Removal of the sub chassis ass'y</b> (DECK 1, DECK 2)	
<b>Procedure</b> 1 → 2 → 5 → 10 → 12 → 13	<ol style="list-style-type: none"> <li>1. Push the drive gear in the direction of arrow ①.</li> <li>2. Remove the 4 screws (① ~ ④).</li> <li>3. Release the 2 claws in the direction of arrow ②, and then remove the connector holder in the direction of arrow ③.</li> <li>4. Remove the sub chassis ass'y in the direction of arrow ④.</li> <li>5. Remove the belt.</li> </ol> <p>Note: Care must be taken to remove the sub chassis ass'y with tweezers that the belt is not applied with grease.</p>	
<b>Ref.No.</b> 14	<b>Removal of the capstan motor</b> (DECK 1, DECK 2)	
<b>Procedure</b> 1 → 2 → 5 → 10 → 12 → 13 → 14	<ul style="list-style-type: none"> <li>• Remove the 2 screws (①, ②).</li> </ul>	

### ■ HOW TO CHECK THE MAIN P.C.B.

1. Remove the cabinet. (See Ref. No.1 of the disassembly instructions.)
2. Remove the power transformer. (See Ref. No.3 of the disassembly instructions.)
3. Remove the rear panel. (See Ref. No.9 of the disassembly instructions.)

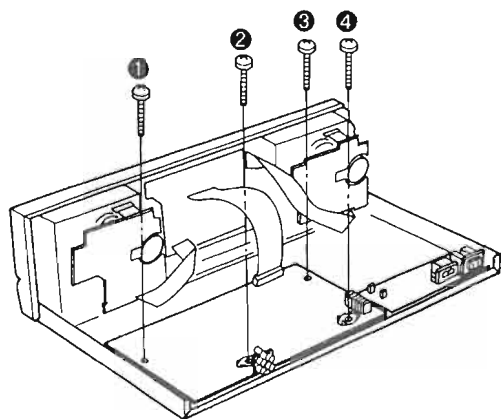

4. Remove the 4 screws (① ~ ④).

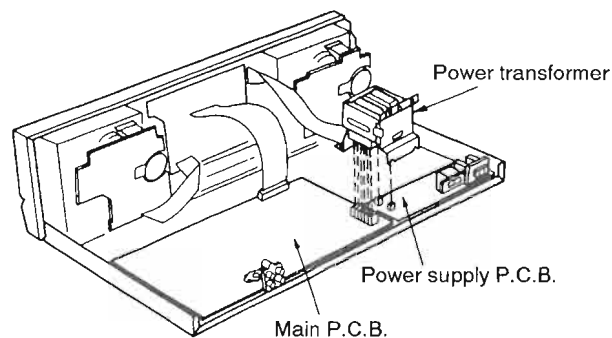

5. Install the power transformer on the main P.C.B. and power supply P.C.B.



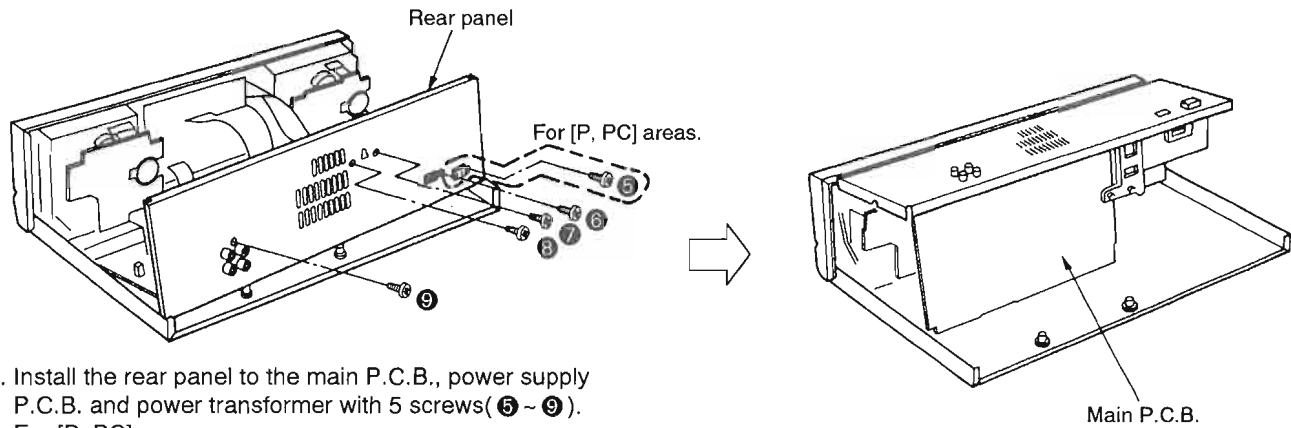

6. Install the rear panel to the main P.C.B., power supply P.C.B. and power transformer with 5 screws( ⑤ ~ ⑨). For [P, PC] areas.
7. Install the rear panel to the main P.C.B., power supply P.C.B. and power transformer with 4 screws( ⑥ ~ ⑨). For [E, EB, EG, GC, GN] areas.

8. When checking the solder surfaces of main P.C.B. and replacing the parts, do as show.

## ■ INSTALLATION OF THE SUB CHASSIS ASS'Y

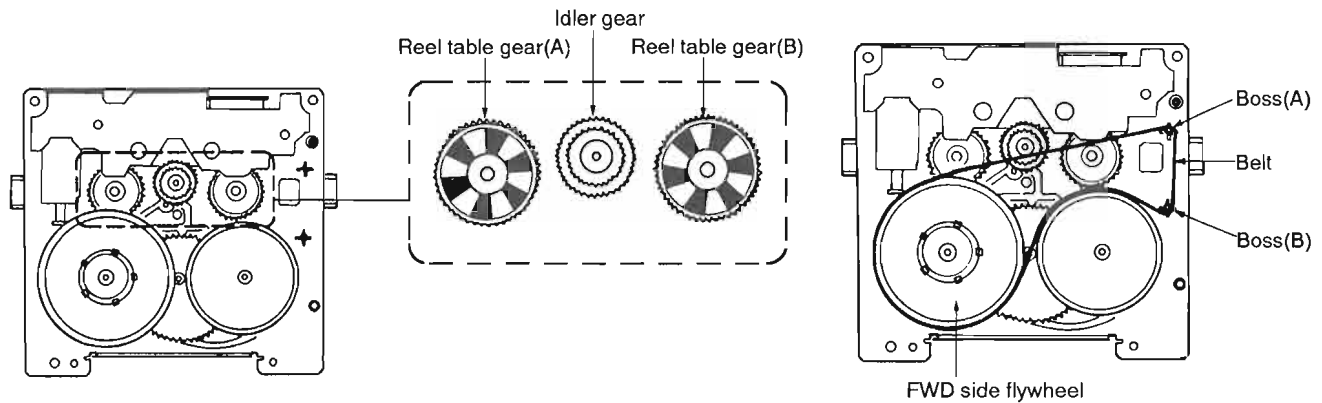

1. Position the idler gear in the between reel table gear(A) and(B). (Mechanism stop position)

2. Temporarily install the belt to the FWD side flywheel, boss(A) and boss(B).  
Note: Care must be taken to install the belt with tweezers that the belt is not applied with grease.

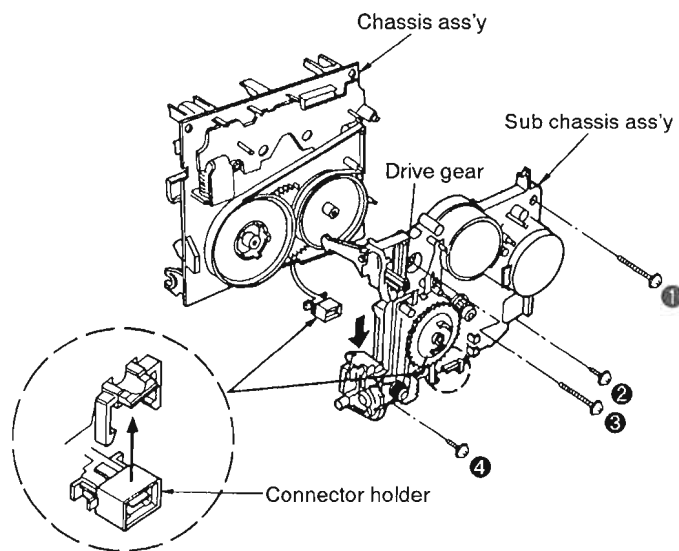

3. Push the drive gear in the direction of arrow.
4. Install the sub chassis ass'y to the chassis ass'y with 4 screws( ① ~ ④).
5. Install the connector holder.

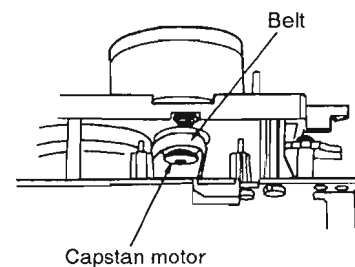
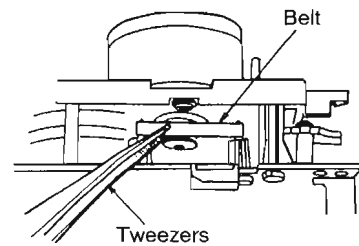

6. Install the belt to the capstan motor using the tweezers.

## ■ INSTALLATION OF THE CASSETTE HOLDER ASS'Y

1. Tilt the rib of cassette holder ass'y at the angle as shown in Fig.1, and then force the cassette holder ass'y to the loading cassette mechanism unit.

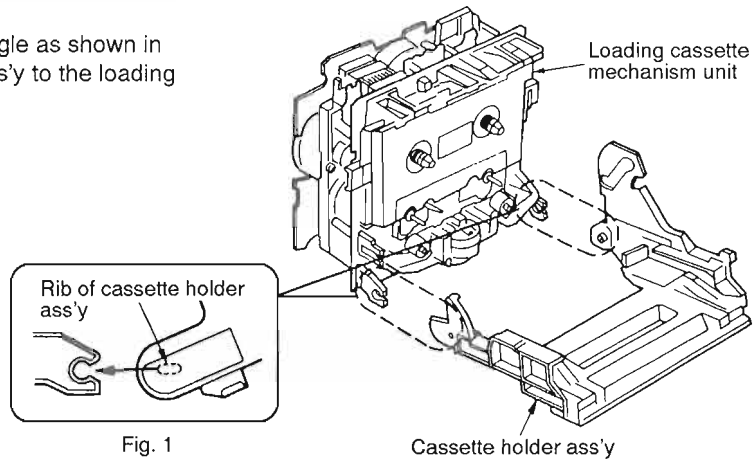
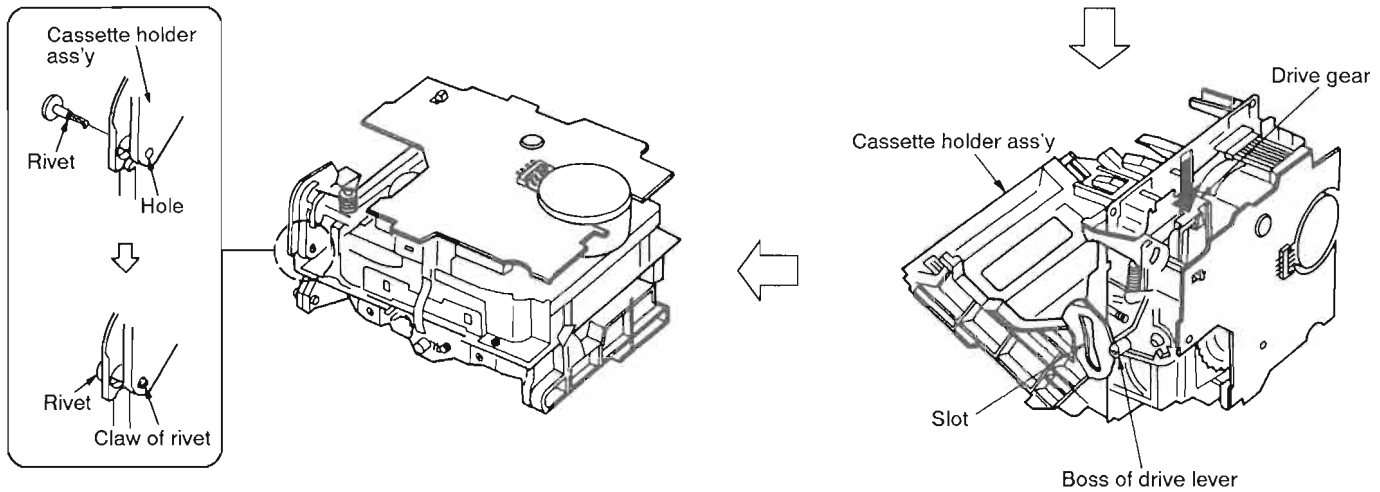

Fig. 1



4. Insert the rivet to the hole of cassette holder ass'y.  
※ Make sure the claw of rivet is positioned in the hole.

2. Push the drive gear in the direction of arrow.
3. Align the boss of drive lever with the slot of cassette holder ass'y.

## ■ WRITING TO EEPROM

This unit is equipped with EEPROM memory that stores a variety of design data and performance data such as playback gain, bias value, recording gain, recording equalization, etc., which was programmed at the factory.

This EEPROM memory is capable of being read and written to more than 100,000 times. To illustrate this, if one ATC operation is performed every hour continuously every day for ten years, it would still be possible to successfully read and write with the EEPROM.

Data is actually written in this EEPROM only when ATC is actuated or when power supply is turned on or off.

Since it hardly breaks down, there will scarcely occur such a trouble as to require replacement.

### Measurement Condition

- Recording-level control; Maximum
- Reverse-mode selector switch; ⇌
- Tape-to-tape recording-speed switch; Off
- Dolby NR switch; Off
- Make sure heads are clean
- Make sure capstan and pressure roller are clean
- Judgeable room temperature  $20 \pm 5^{\circ}\text{C}$  ( $68 \pm 9^{\circ}\text{F}$ )

### Measuring instrument

- EVM (Electronic Voltmeter)
- Oscilloscope
- AF oscillator
- ATT (Attenuator)
- Resistor ( $600\Omega$ )

**NOTE:** Before adjustment, be sure to set the AF oscillator output level to 0dB (1kHz): 1V

### Test tape

- Playback gain adjustment (315Hz, 0dB); QZZCFM
- Overall gain adjustment and Overall frequency response  
Normal reference blank tape; QZZCRA  
CrO<sub>2</sub> reference blank tape; QZZCRX1  
Metal reference blank tape; QZZCRZ5

**NOTE:** Step 2 to step 7 only has to be done after exchange of the EEPROM.

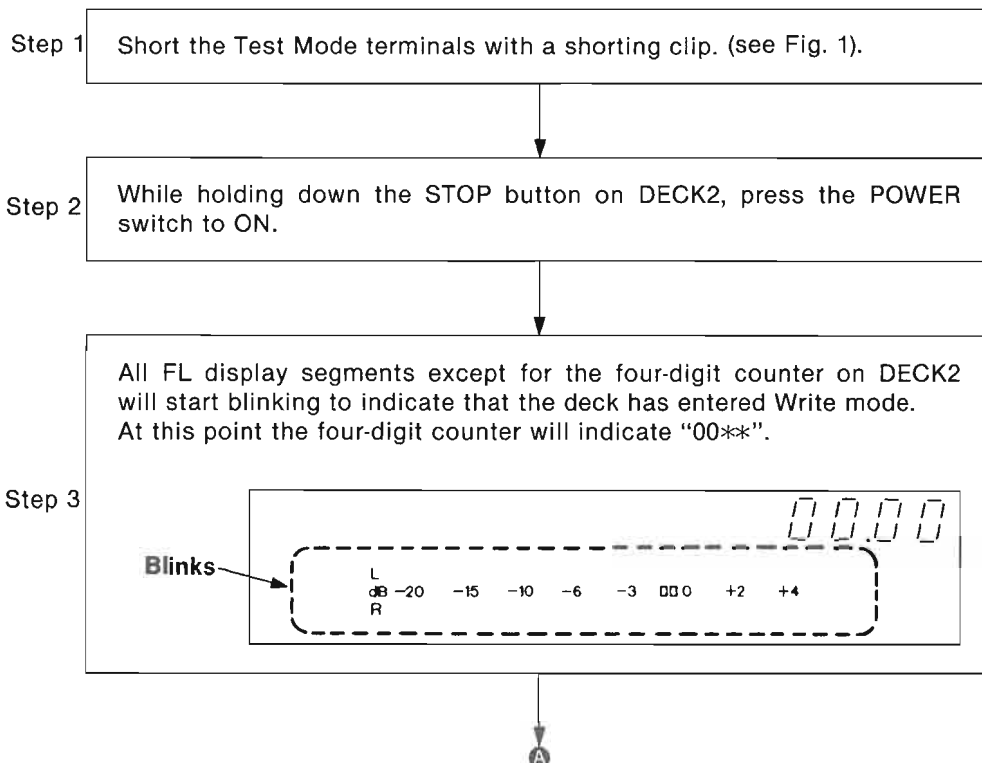

OPERATION P.C.B.

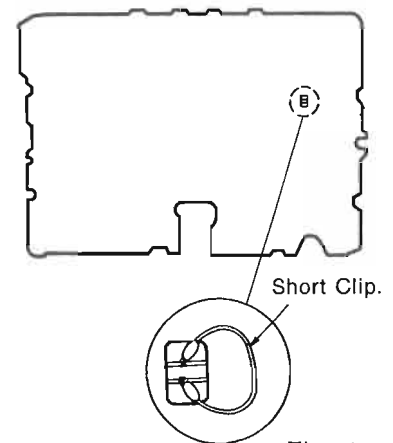

### Notes:

- The test mode terminals on main P.C.B. should be shorted with a short clip as shown above figure.
- After the adjustment items disconnect the short clip.

**Step 4** The counter shows a four-digit hex number. The two high-order digits indicate a ROM address, and the two low-order digits indicate the data stored at that address.

**Step 5**

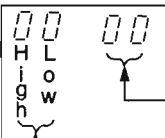

Set these digits using the FF or REW button. The high- and low-order digits of the address increment alternately each time the FF button is pressed. The REW button causes these digits to decrement alternately. For fast incrementing or decrementing, hold down the FF or REW button.

Set these digits using the F. PLAY or R. PLAY button. The high- and low-order digits of the data increment alternately each time the F. PLAY button is pressed. The R. PLAY button causes these digits to decrement alternately. For fast incrementing or decrementing, hold down the F. PLAY or R. PLAY button.

Example: Set "5A" in address 03 (see Fig. 3).

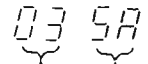

Set these digits to "5A" using the F. PLAY or R. PALY button.

Set these digits to "03" using the FF or REW button.

**Step 6** Begin from address 00 and write data up to address 7F (data in ). Check that the data at address 7F is "00" (end), and then exit the write mode.

**Step 7** After completing ROM writing, press the STOP button on DECK2 to restore the normal Test mode. The four-digit counter on DECK1 displays.

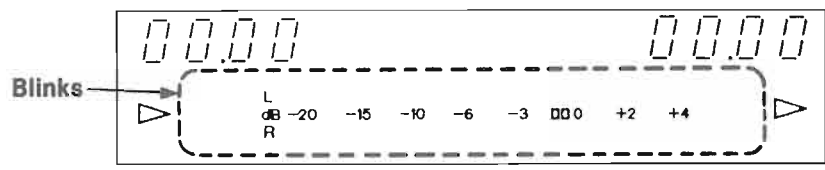

**PLAYBACK GAIN**

**Step 8**

- Set the AF oscillator's output frequency to 315Hz/-20dB (100mV) (see Fig. 2).
- With no tape loaded in the deck, press and hold the REC button. Adjust the test signal level using the Rec. Level controls until the line output levels on both channels are 320mV. When the adjustment is complete, release the REC button. (The deck stores the data at the moment the REC button is released.)
- Load the test tape, QZZCFM, into the deck and locate the section of the tape where the playback gain test tone (315Hz, 0dB) is recorded, then playback the portion. Press the ARM button, and the display will flash **M** slowly, meaning that playback gain is being automatically adjusted. Press the play button. (At this point the deck automatically adjusts playback gains.) After this play back the tape and verify that the output level falls in the specified range.

**Standard value: 320mV ± 0.5dB**

**Note:** If adjustment of PLAYBACK GAIN fails, the display will flash **M** rapidly. After a successful adjustment, the display will no longer show **M**.

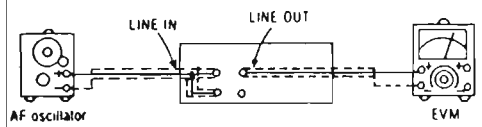

Fig. 2

**A**

**INITIAL SETTING UP FOR OVERALL GAIN  
AND OVERALL FREQUENCY RESPONSE**

B

Step 9

- Load a Normal blank test tape (QZZCRA) into the deck under test. Press the ARM button, then the REC button. The display will flash **M** slowly. (At this point the deck automatically adjusts the overall gain and frequency response.)
  - After the above setting, the overall gain for selection of CrO<sub>2</sub> and Metal tape will be automatically set by the ROM and stored in the ROM.
- Note:** If adjustment of OVERALL GAIN or OVERALL FREQUENCY RESPONSE fails, the display will flash **M** rapidly. After a successful adjustment, the display will no longer show **M**.

Step 10

Remove the shorting clip from the Test Mode terminals. The FL display will stop blinking.

**Note:** If the microprocessor is replaced, it is not necessary to replace (or write data to) the EEPROM.

• **EEPROM MAP**

High Low	0	1	2	3	4	5	6	7
0	00	—	—	—	—	—	—	—
1	—	—	—	—	—	—	—	—
2	—	—	—	—	—	—	—	—
3	5A	—	—	—	—	—	—	—
4	—	—	—	—	—	68	84	90
5	—	—	—	—	—	78	60	60
6	—	—	—	—	—	38	30	18
7	—	—	—	—	—	64	68	78
8	—	—	—	—	—	A8	B0	8C
9	—	—	9A	AA	94	50	70	68
A	—	—	6A	0F	—	80	80	80
B	—	—	70	2B	—	40	50	A0
C	—	—	50	12	—	B8	B4	B8
D	—	—	72	07	—	66	5E	40
E	—	—	4C	FB	—	70	74	02
F	—	—	55	F5	—	47	47	00

Fig. 3

**Note:** At an address with no data value indicated (e.g. 01 → —), the ROM operates normally irrespective of the kind of the data supplied.

## MEASUREMENTS AND ADJUSTMENTS

### Measurement Condition

- Recording-level control; Maximum
- Reverse-mode selector switch;  $\rightleftharpoons$
- Tape-to-tape recording-speed switch; Off
- Dolby NR switch; Off
- Make sure heads are clean
- Make sure capstan and pressure roller are clean
- Judgeable room temperature  $20 \pm 5^{\circ}\text{C}$  ( $68 \pm 9^{\circ}\text{F}$ )

### Measuring instrument

- EVM (Electronic Voltmeter)
- Oscilloscope
- Digital frequency counter
- AF oscillator
- ATT (Attenuator)
- DC voltmeter
- Resistor ( $600\Omega$ )

**NOTE:** Before adjustment, be sure to set the AF oscillator output level to 0dB (1kHz): 1V

### Test tape

- Head azimuth adjustment (8kHz, -20dB)
- Playback frequency response (315Hz, 12.5kHz, 10kHz, 8kHz, 4kHz, 1kHz, 250Hz, 125Hz, 63Hz, -20dB)
- Playback gain adjustment (315Hz, 0dB)
- Tape speed adjustment (3kHz, -10dB); QZZCWAT
- Overall gain adjustment and Overall frequency response  
Normal reference blank tape; QZZCRA  
CrO<sub>2</sub> reference blank tape; QZZCRX1  
Metal reference blank tape; QZZCRZ5

### Adjustment Points

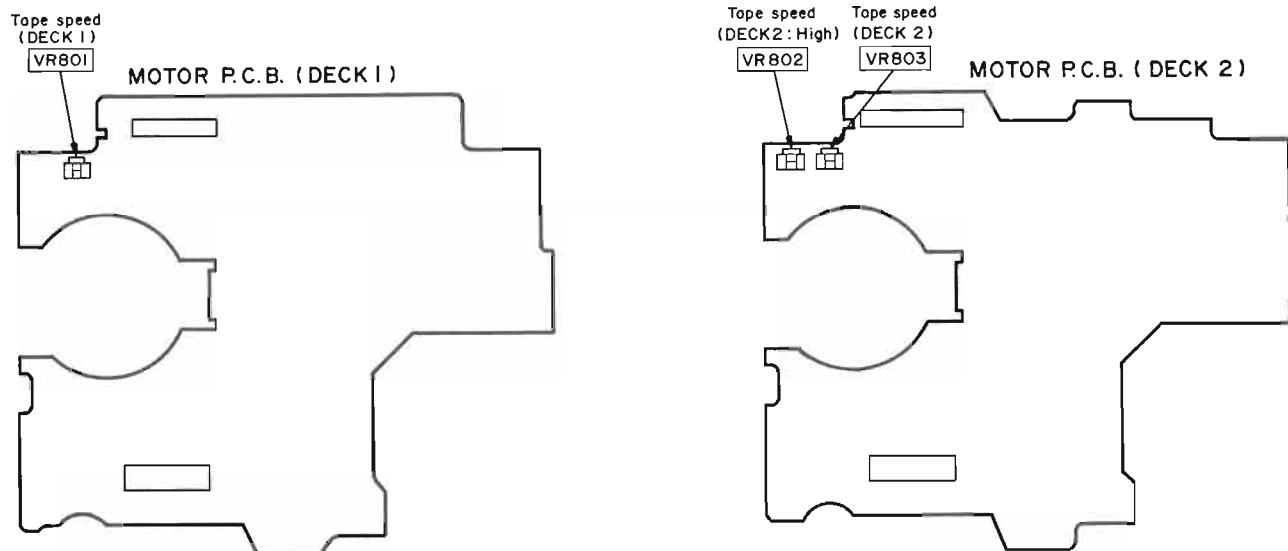

### OPERATION P.C.B.

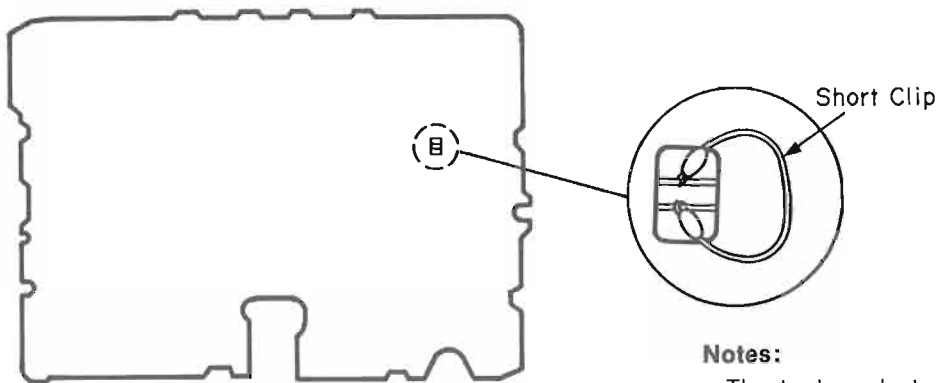

### Notes:

- The test mode terminals on mechanism control P.C.B. should be shorted with a short clip as shown above figure.
- After the adjustment items disconnect the short clip.

## HEAD REPLACEMENT

When replacing the R/P head or E head, adjust the head azimuth (erase head with small screw stop does not need adjustment) then start the EEPROM adjustment in the following sequence.

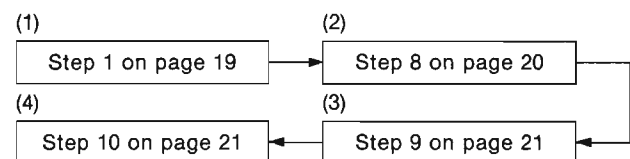

(The adjustment is necessary because the playback gain, the overall gain, and the overall frequency response are changed by the head replacement.)

## HEAD AZIMUTH ADJUSTMENT (DECK 1/2)

1. Playback the azimuth adjustment portion (8kHz, -20dB) of the test tape (QZZCFM). Vary the azimuth adjusting screw until the output of the R-CH are maximized.
2. Perform the same adjustment in the play mode.
3. Repeat the same check in reverse play mode.
4. After the adjustment, apply screwlock to the azimuth adjusting screw.

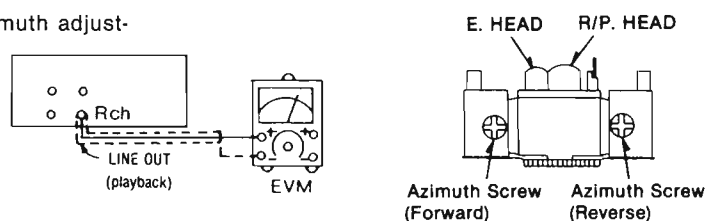

## TAPE SPEED ADJUSTMENT (DECK 1/2)

### Normal speed

1. Playback the middle portion of the test tape (QZZCWAT).
2. Short the test terminal.
3. Adjust Deck 1=VR801 and Deck 2=VR803 so that the output is within the standard value.

**Standard value: 3000 ± 15 Hz (NORMAL speed)**

### High speed [Set the unit to forward (FWD) mode.]

4. Press the tape-to-tape recording-speed selector switch (X2) button. This will set the high speed mode.
5. Playback the middle portion on the test tape (QZZCWAT).
6. At that time, check if the output from DECK 1 is within the standard value.

**Standard value: 6000 ± 600 Hz (HIGH speed)**

7. Adjust VR802 so that the output frequency of DECK 2 is within ±30 Hz for the value of the output frequency of DECK 1.
8. Release the test terminal.

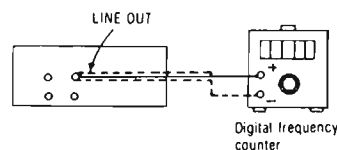

## PLAYBACK GAIN MEASUREMENT (DECK 1/2)

1. Load the test tape (QZZCFM) into the deck and locate the part where the playback gain test tone (315Hz, 0dB) is recorded. After this, play back the tape and verify that the output level falls in the specified range.

**Standard value: 320mV ± 0.5dB**

2. If outside the standard value, data in EEPROM should be written again by taking the following procedure and thereafter section 1 should be carried out again.

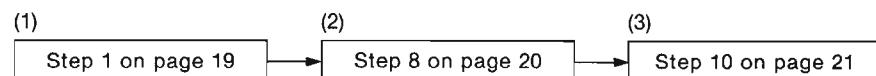

## PLAYBACK FREQUENCY RESPONSE (DECK 1/2)

1. Playback the frequency response portion (315Hz, 12.5kHz~63Hz, -20dB) of the test tape (QZZCFM).
2. Assure that the frequency response is within the range shown in Fig. 4 for both L-CH and R-CH.

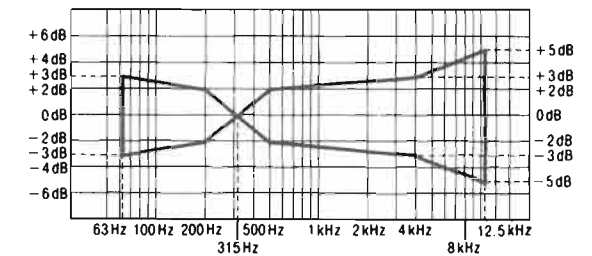
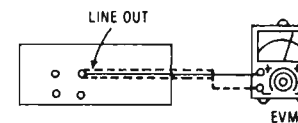
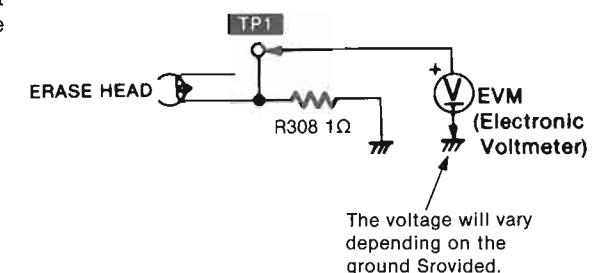

Fig. 4

## ERASE CURRENT ADJUSTMENT

1. With no tape loaded in the deck, press the Record button.
2. Check if the output at this time between the erase current confirmation point TP1 and GND (chassis) is within the standard value.

**Standard value: 175 ± 15 mA (Metal)  
EVM Reading: 175 ± 15 mV (L303 case → TP1)**



## CONFIRMATION OF THE OVERALL GAIN AND OVERALL FREQUENCY RESPONSE

1. In the Record Pause mode, load a normal blank tape (QZZCRA) into the deck, and apply the reference input signal (1kHz, -24dB) to the Rec. input. Adjust the output to 320mV with the attenuator, and start recording.
2. While playing back the reference signal just recorded, verify that the output level falls in the following range.

**Standard value: 320mV ± 0.5dB**

3. Afterward, apply a signal (frequency at the measured point in the range from 50Hz to 10kHz), whose level is 20dB lower than the reference signal level (1kHz, -24dB=approx. 63mV), to the Rec. input. Then start recording with a normal blank tape (QZZCRA).
4. Play back the test signals just recorded and verify that the levels at the test frequencies fall in the ranges specified in Fig. 5 with respect to the reference signal level.
5. Repeat steps 3 and 4 above for CrO<sub>2</sub> blank test tape (QZZCRX1) and Metal blank test tape (QZZCRZ5), in these cases raising the upper end of the test signal frequency range to 12.5kHz. Verify that the signal levels at the test frequencies fall in the ranges specified in Fig. 6 with respect to the reference signal level.

Steps 1 through 2 above are concerned with overall gain; steps 3 through 5 pertain to overall frequency response.

6. If outside the standard value, data in EEPROM should be written again by taking the following procedure and thereafter section 1-5 should be carried out again.



### Normal Overall frequency response chart (NR OUT)

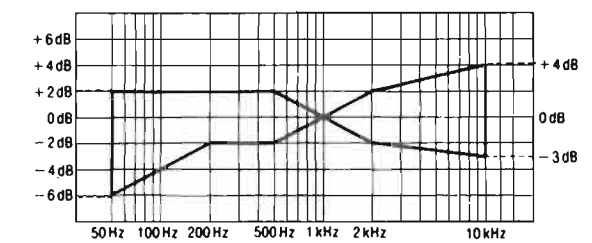

Fig. 5

### CrO<sub>2</sub> Metal Overall frequency response chart (NR OUT)

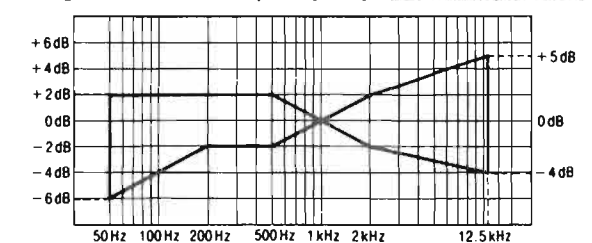
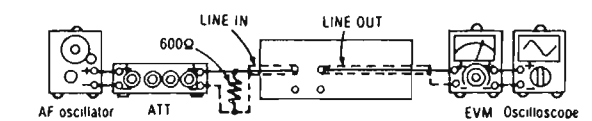
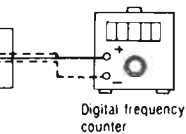
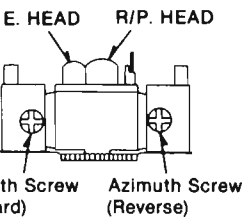

Fig. 6



ow stop does not need

y response are changed



ut frequency of DECK 1.

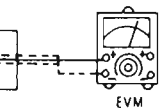

ng procedure and there

**PLAYBACK FREQUENCY RESPONSE (DECK 1/2)**

1. Playback the frequency response portion (315Hz, 12.5kHz~63Hz, -20dB) of the test tape (QZZCFM).
2. Assure that the frequency response is within the range shown in Fig. 4 for both L-CH and R-CH.

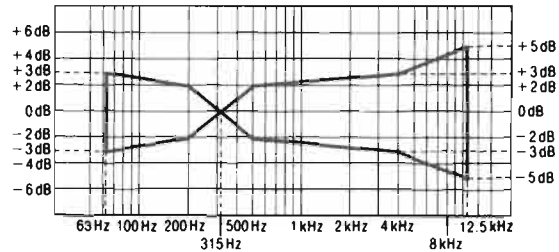
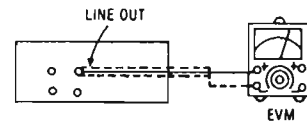
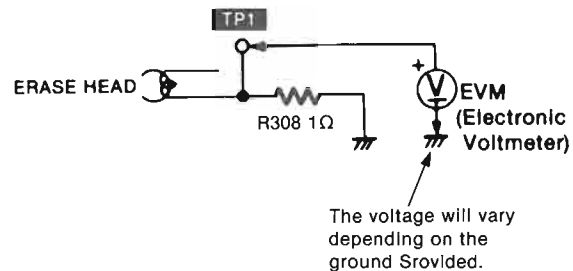

Fig. 4

**ERASE CURRENT ADJUSTMENT**

1. With no tape loaded in the deck, press the Record button.
2. Check if the output at this time between the erase current confirmation point TP1 and GND (chassis) is within the standard value.

**Standard value: 175 ± 15 mA (Metal)**  
**EVM Reading: 175 ± 15 mV (L303 case → TP1)**



The voltage will vary depending on the ground provided.

**CONFIRMATION OF THE OVERALL GAIN AND OVERALL FREQUENCY RESPONSE**

1. In the Record Pause mode, load a normal blank tape (QZZCRA) into the deck, and apply the reference input signal (1kHz, -24dB) to the Rec. input. Adjust the output to 320mV with the attenuator, and start recording.
2. While playing back the reference signal just recorded, verify that the output level falls in the following range.

**Standard value: 320mV ± 0.5dB**

**Normal Overall frequency response chart (NR OUT)**

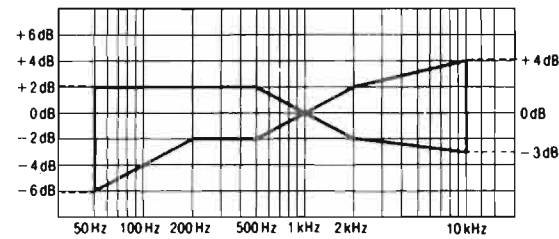

Fig. 5

**CrO<sub>2</sub> Metal Overall frequency response chart (NR OUT)**

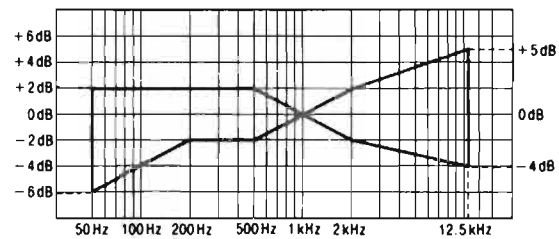
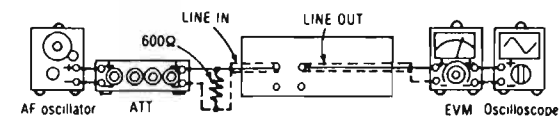

Fig. 6



3. Afterward, apply a signal (frequency at the measured point in the range from 50Hz to 10kHz), whose level is 20dB lower than the reference signal level (1kHz, -24dB=approx. 63mV), to the Rec. input. Then start recording with a normal blank tape (QZZCRA).
4. Play back the test signals just recorded and verify that the levels at the test frequencies fall in the ranges specified in Fig. 5 with respect to the reference signal level.
5. Repeat steps 3 and 4 above for CrO<sub>2</sub> blank test tape (QZZCRX1) and Metal blank test tape (QZZCRZ5), in these cases raising the upper end of the test signal frequency range to 12.5kHz. Verify that the signal levels at the test frequencies fall in the ranges specified in Fig. 6 with respect to the reference signal level.

Steps 1 through 2 above are concerned with overall gain; steps 3 through 5 pertain to overall frequency response.

6. If outside the standard value, data in EEPROM should be written again by taking the following procedure and there thereafter section 1-5 should be carried out again.

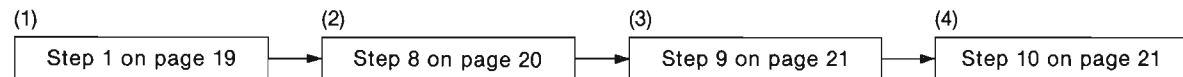

**WIRING CONNECTION DIAGRAM**

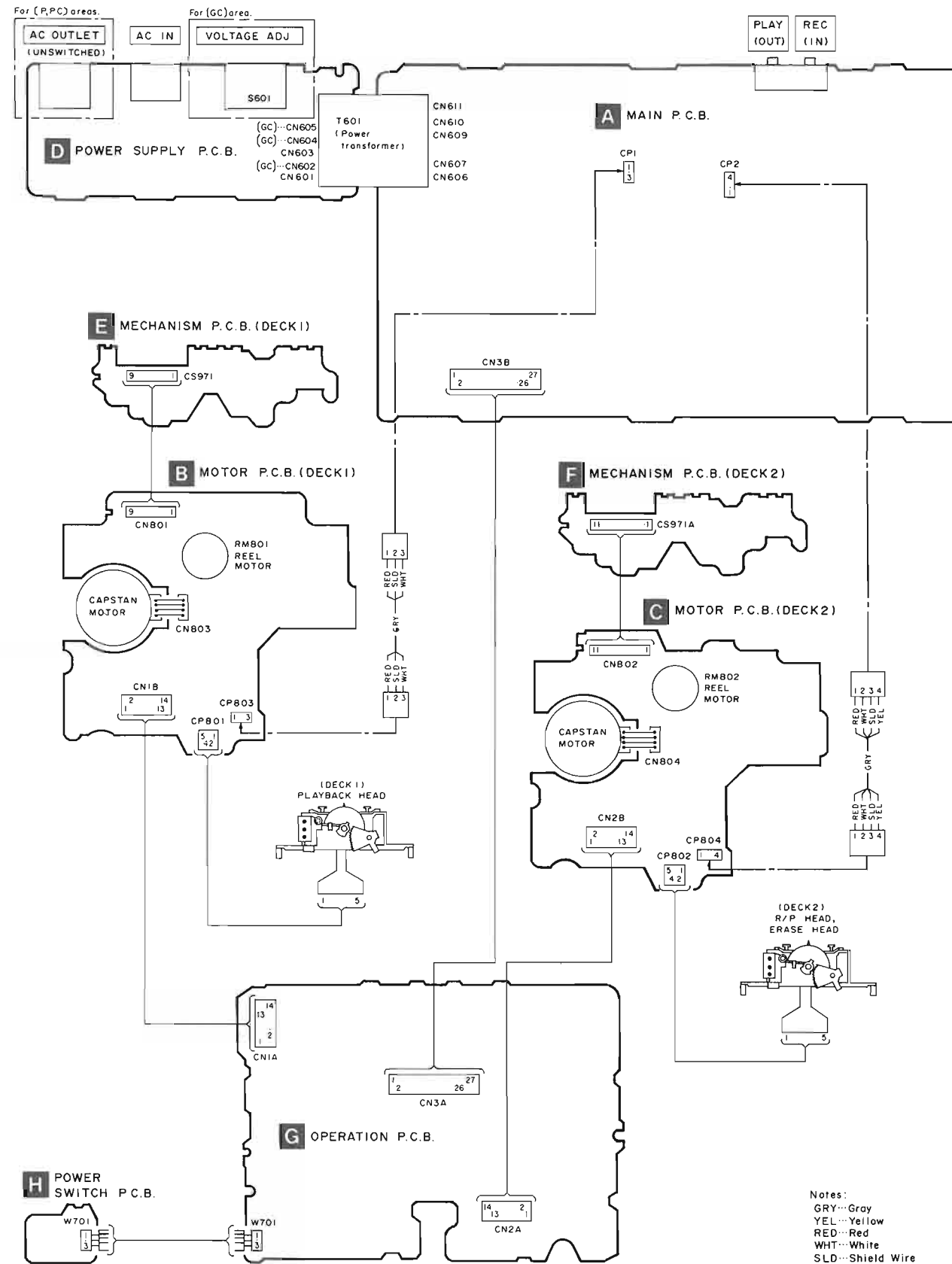

Notes:  
 GRY...Gray  
 YEL...Yellow  
 RED...Red  
 WHT...White  
 SLD...Shield Wire



# ■ TROUBLESHOOTING GUIDE

\*To perform troubleshooting, set the unit to the state described in the "Motor Control PCB Checking Method" on page 22.

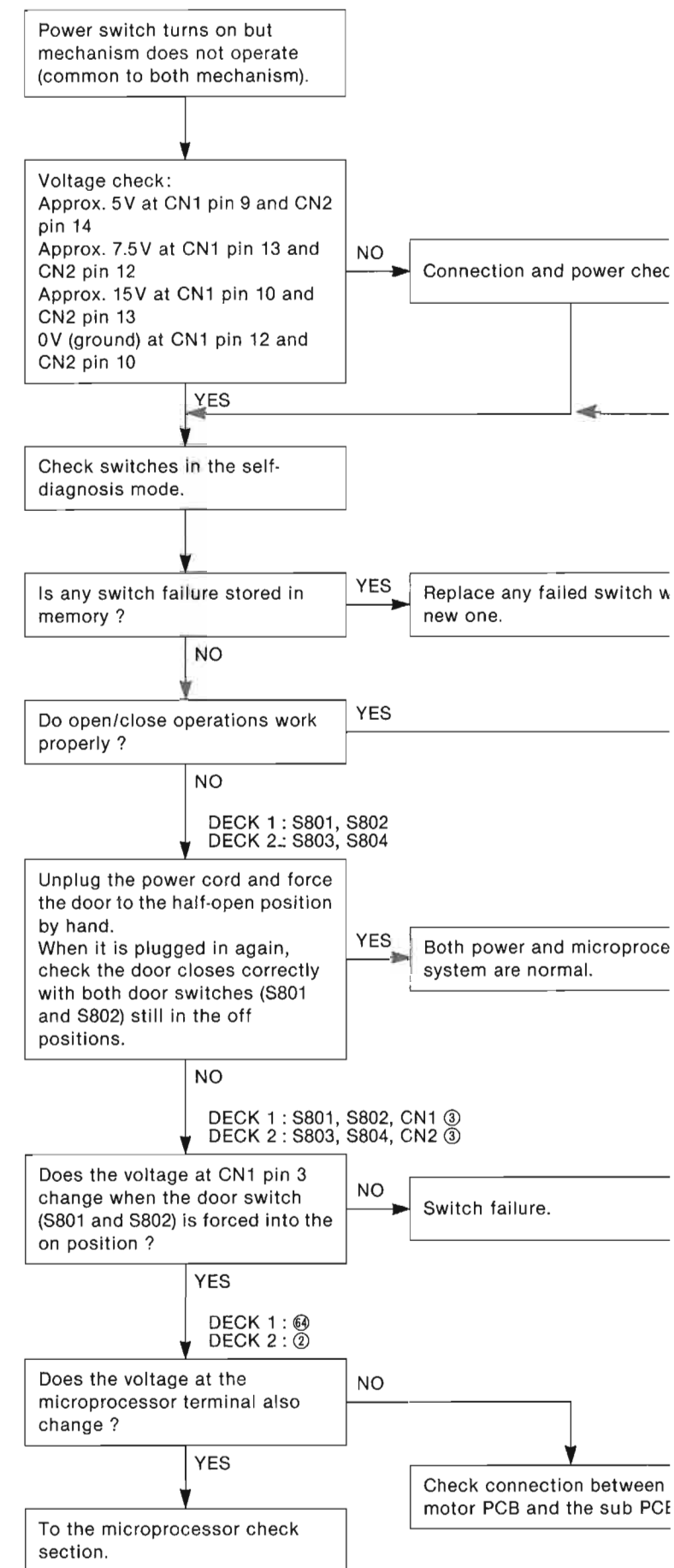
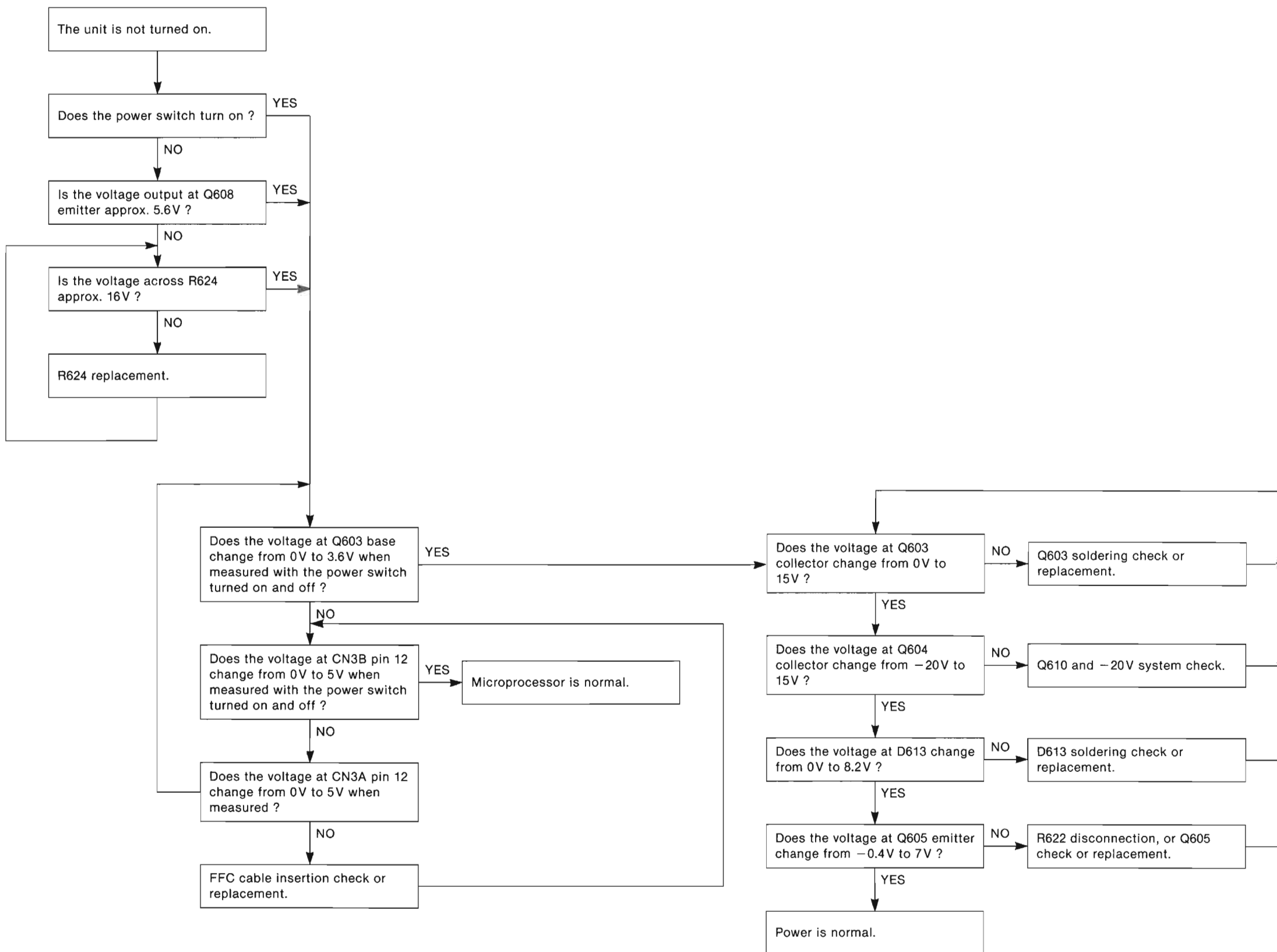

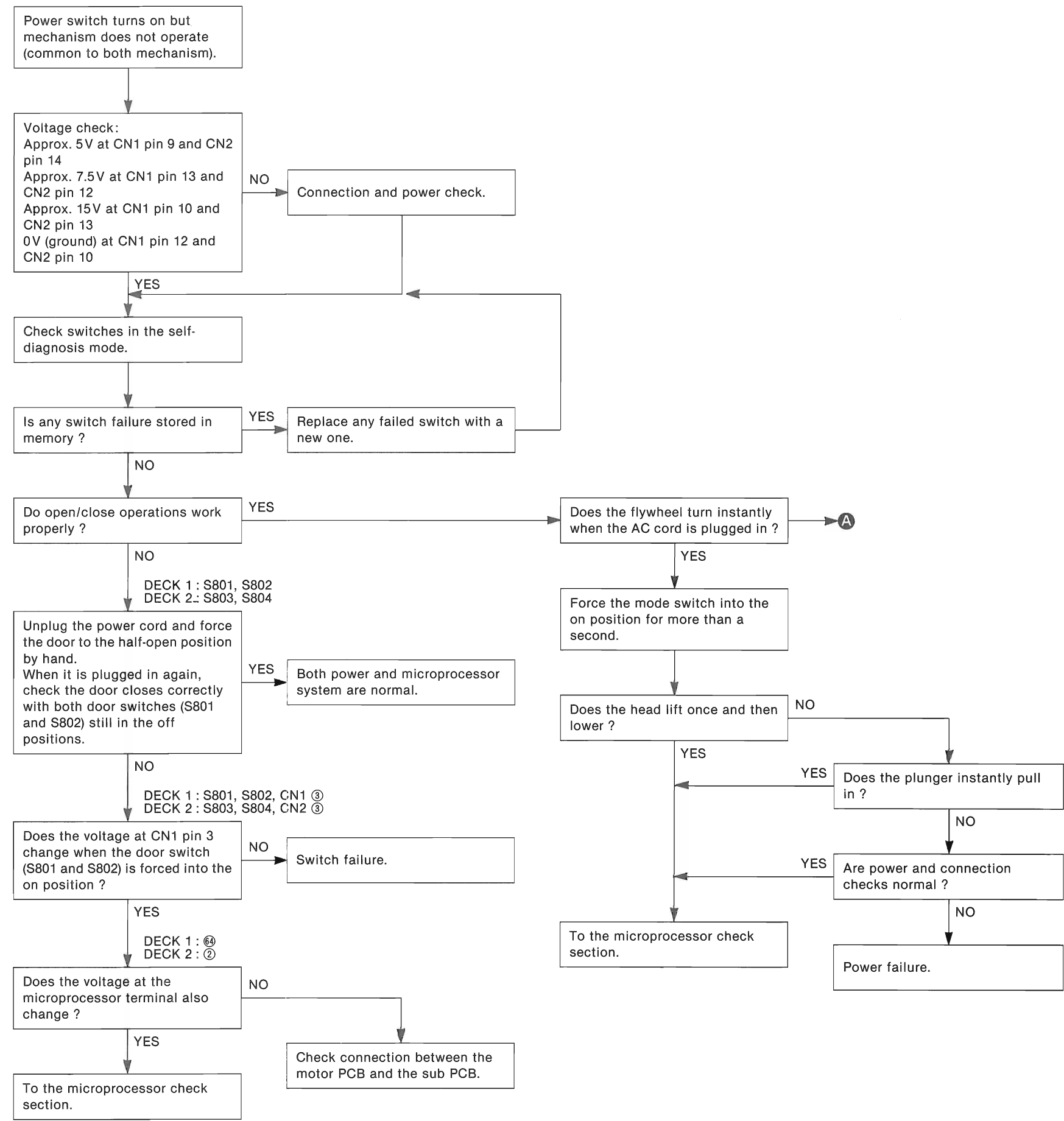
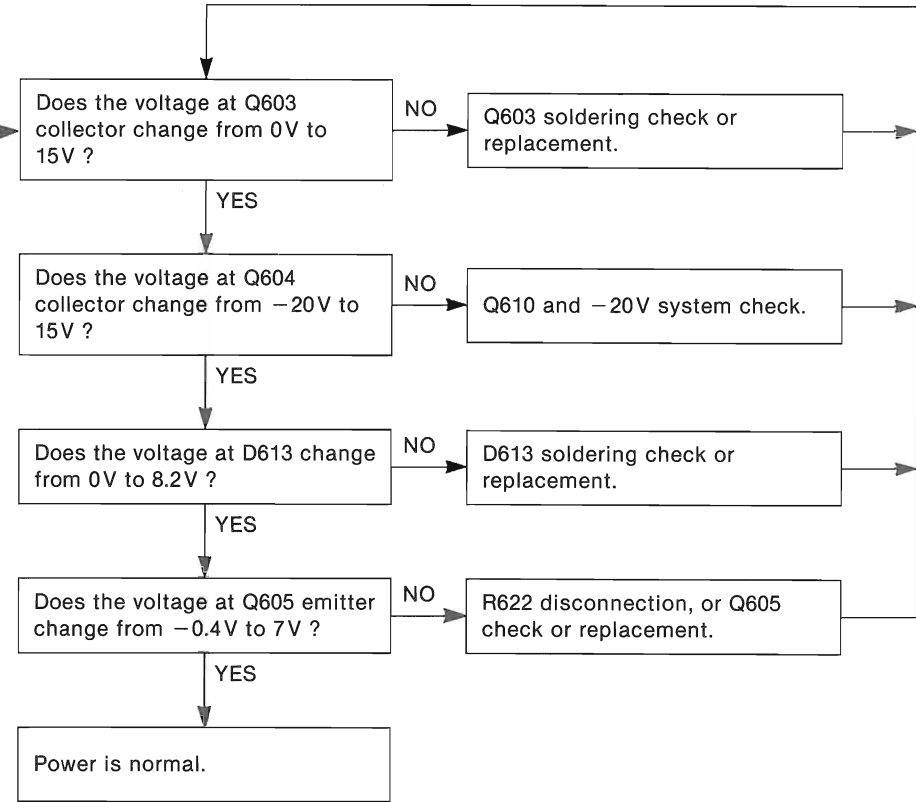

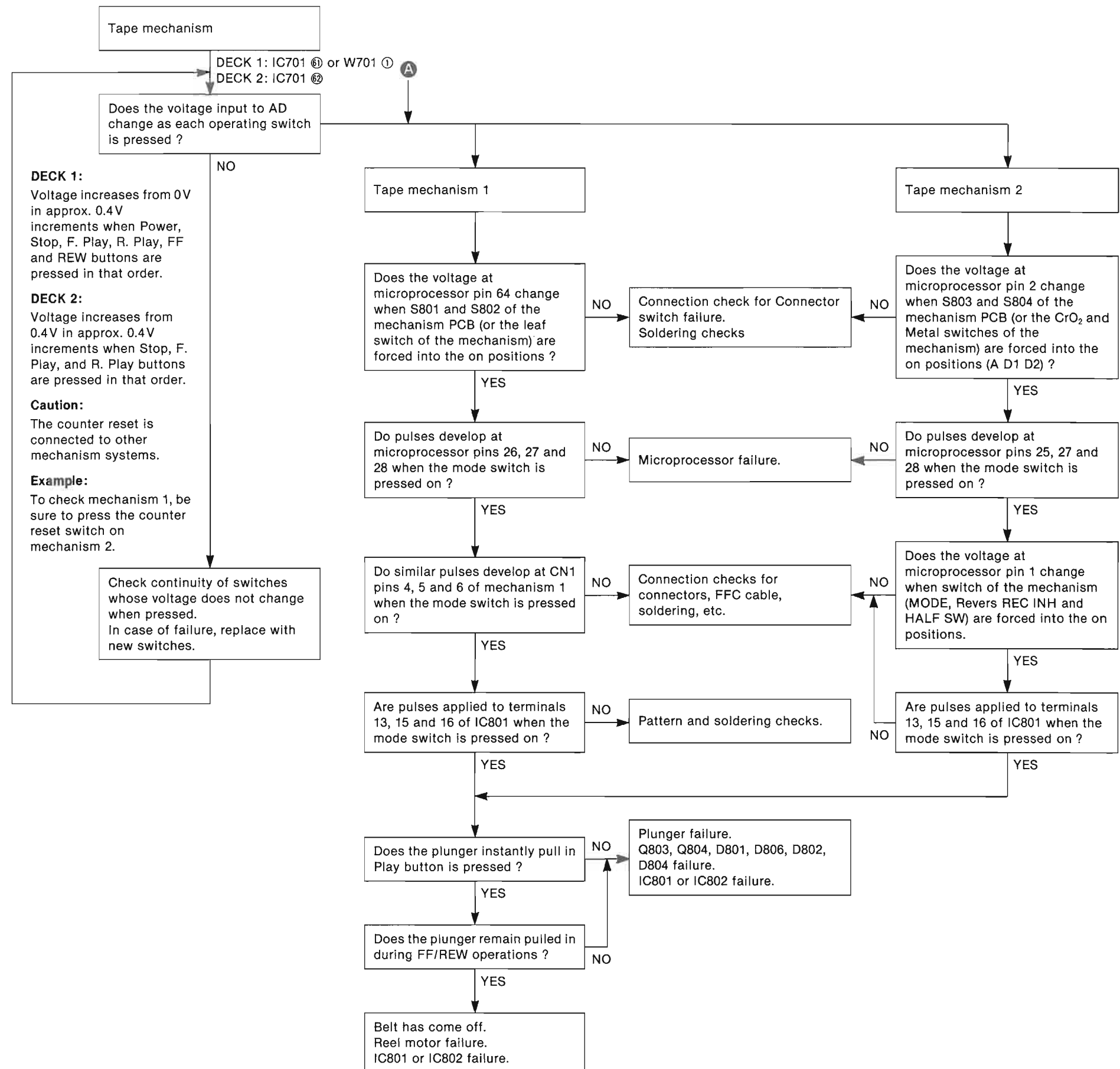
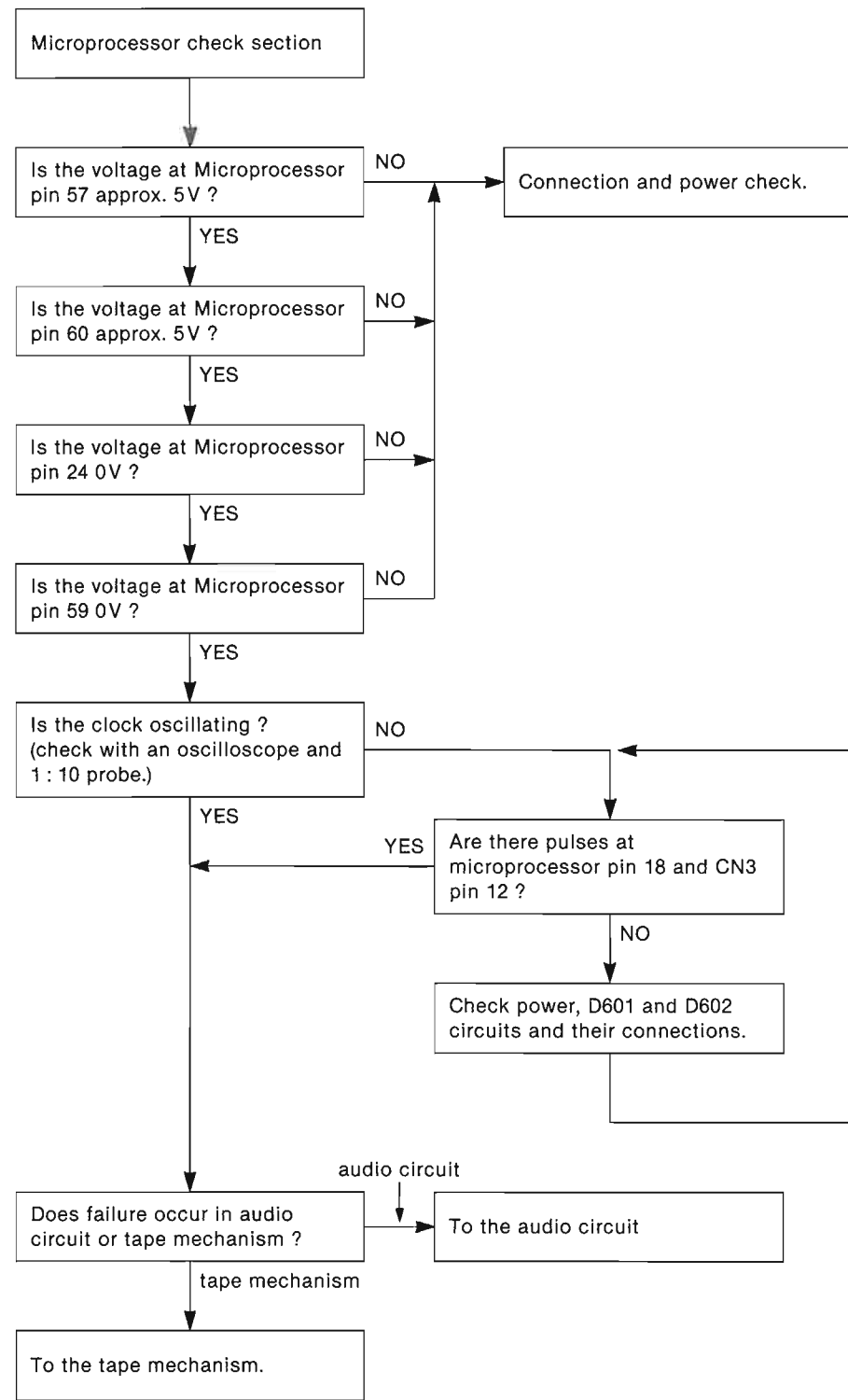

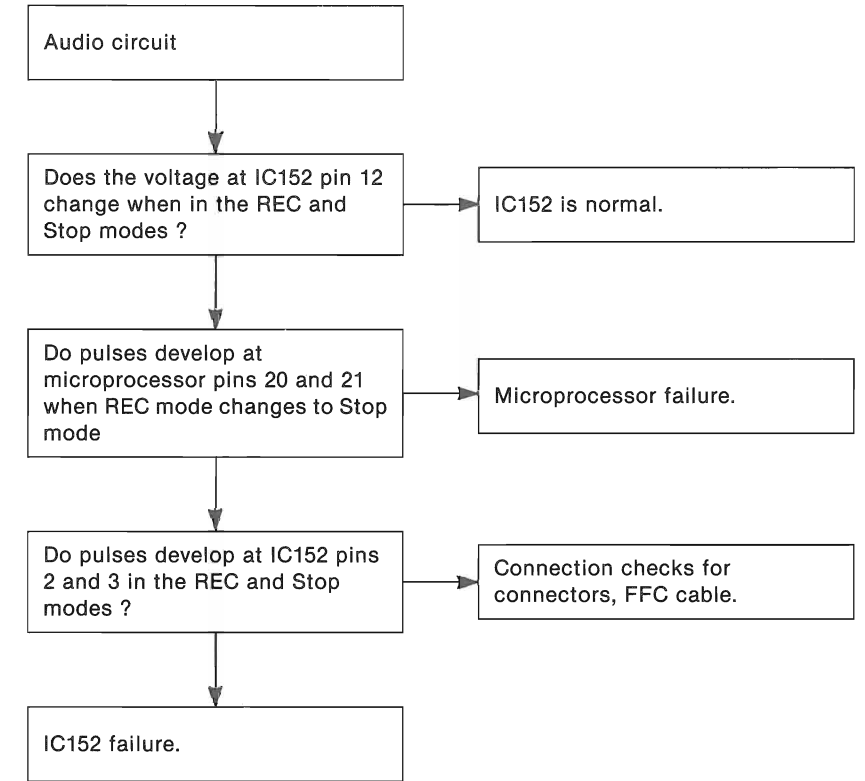
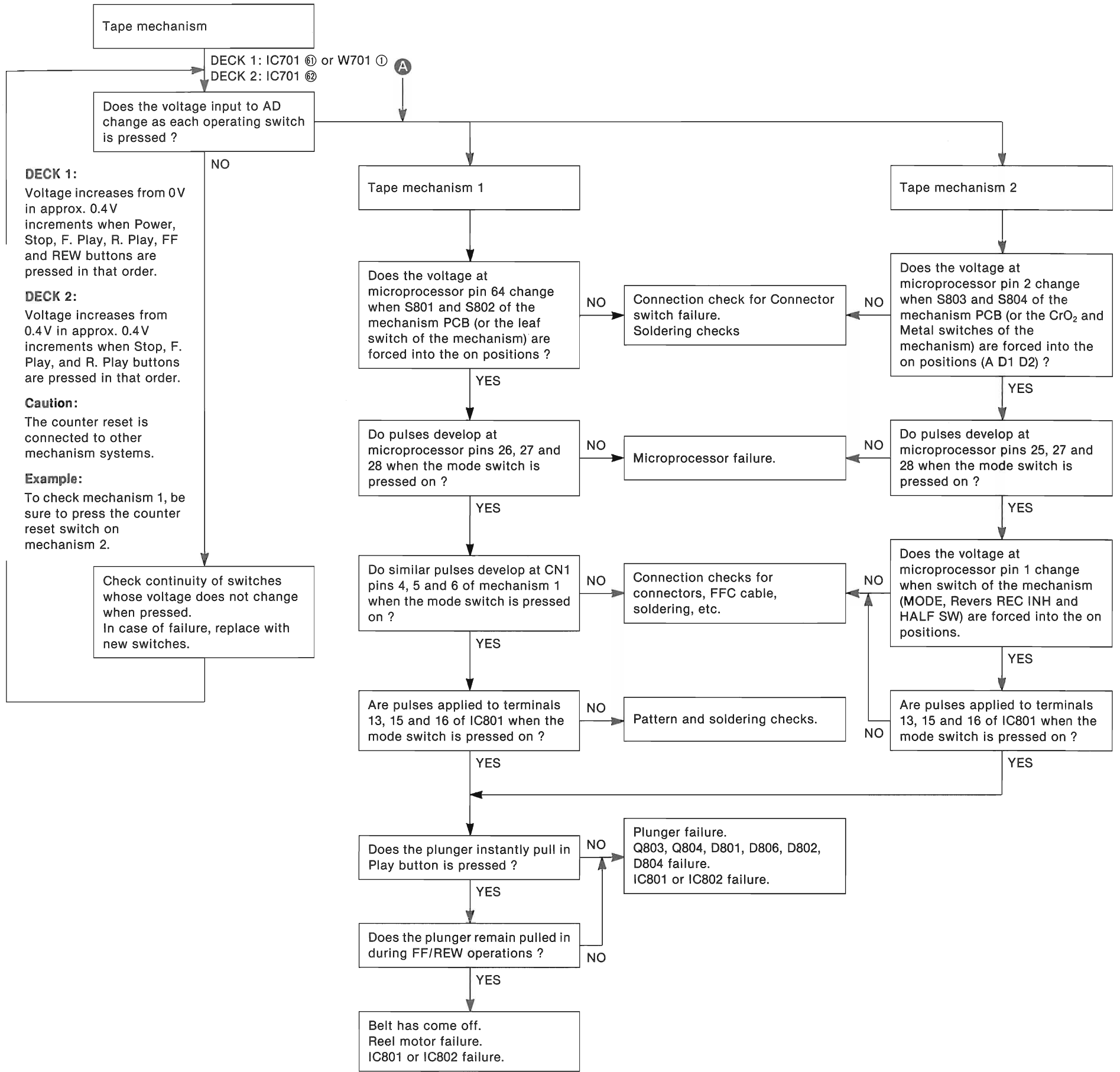





- As shown above, check the voltage at each pin of IC152 for the following:
- ① Equalizer 120μs/70μs change.
  - ② Dubbing seed does not change.
  - ③ Erase current does not change between the CrO<sub>2</sub> and Normal/Metal tape. (Erase current for CrO<sub>2</sub> and Normal tape is the same.)
  - ④ Deck 1 and deck 2 produces no change.
  - ⑤ Dolby off, B and C produces no change.
  - ⑥ REC and Play produces no change.
  - ⑦ Auto REC mute does not operate.

## ■ TERMINAL FUNCTION OF IC

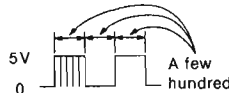

### • IC701 (M38123M4101F): MICROCOMPUTER

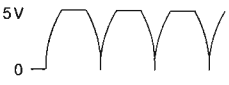
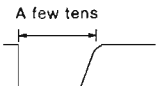
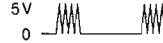
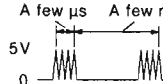

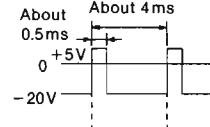
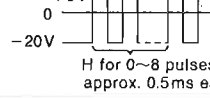

\* To check the contents of the item "※" in the IC terminal table, set the unit to the state described in the "Motor Control PCB Checking Method" on page 22.

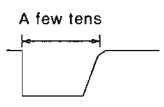
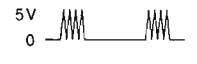
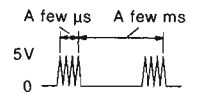
Pin No.	Mark	I/O Division	Function	Check point	※ Description
1	AD2D2	I	Deck 2 Mechanism switch (MODE, RINH, HALF) input	Connector CN2A ④ pin CN802 ⑤ pin	No tape load: Approx. 4.1V Normal tape with tab: Approx. 2.3V
2	AD1D2	I	Deck 2 Mechanism switch (FINH, CrO <sub>2</sub> , Metal, OPEN/CLOSE) input	Connector CN2 ③ pin	No tape load: Approx. 4.1V Normal tape with tab: Approx. 0V Chrome tape with tab: Approx. 1.1V Metal tape with tab: Approx. 1.7V
3	METER-R	I	Rch indication level input	Connector CN3 ② pin	0V with no signal and 1V with 0VU (-20dB) input in the REC or PAUSE mode. The voltage varies from 0 to 5V for different input levels.
4	METER-L	I	Lch indication level input	Connector CN3 ① pin	
5	TEST		Test mode input	IC701 ⑤ pin	Normal: "H" (=4.8V) Test (Service) mode: "L" (=0V)
6	POWER	O	Power control output ON: "H", OFF: "L"	Connector CN3 ⑬ pin	Power ON: "H" (=5V) Power OFF: "L" (=0V)
7	MODEL	I	Model selector terminal	IC701 ⑦ pin	Normal: "L" (=0V) The deck malfunctions when set to "H".
8	MSP	I	TPS signal det. input ON: "L", OFF: "H"	Connector CN3B ⑧ pin	TPS mode No program: "H" (=5V) Programs: "L" (=0V)
9	—	—	Not used	—	—
10	DMT	O	Line out mute signal output ON: "L", OFF: "H"	Connector CN3 ⑭ pin	"L" (=0V) when sound is being produced in the play or REC mode and "H" (=2.5~5V) when no sound is produced in the stop of FF/REW mode.
11	ECS	O	E2PROM chip select signal ON: "H", OFF: "L"	Connector CN704 ① pin CN704 ⑤ pin	 (ex...For ↑ REV PLAY mode is changed)
12	ECLK	O	E2PROM serial clock output ON: "L", OFF: "H"	Connector CN704 ② pin CN704 ④ pin	 Waveform appears in response to 11 above.
13	EDAT	I/O	E2PROM serial data input/output	Connector CN704 ③ pin	(ex...For ↔ REV PLAY mode is changed) Waveform appears in response to 11 above.
14	PBADJ	O	Playback adj. output ON: "H", OFF: "L"	Connector CN3 ⑦ pin	Used for adjustment at factory but in the finished product. Remains at "L" (=0V).
15	OSC	O	Audio signal for adjustment output	Connector CN3 ⑥ pin	Generated signals at approx. 400Hz, 10kHz and 3kHz (square wave (H and L, 0 and 5V) in REC mode during adjustment of ARM).
16	STB	O	Strobe (load) output for the DA converter (IC151)	Connector CN3 ⑪ pin	Used to load output for the DA converter (IC151).
17	REMOTE	I	Remocon signal input ON: "H", OFF: "L"	Z701 ① pin	H and L pulse waveform appears on the input of a remote control signal.

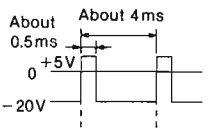
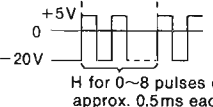
Pin No.	Mark	I/O Division	Function	Check point	※ Description
18	POF	I	Power off det. input ON: "H", OFF: "L"	Connector CN3 ⑫ pin	 Rectified waveform at both 50 and 60Hz (clamping at 5V) The microprocessor goes into standby mode when this signal is removed.
19	RESET	I	Reset input ON: "L", OFF: "H"	IC701 ⑩ pin	 Usually H (=5V) but L for a period of a few to a few tens of milliseconds is first plugged in when the player.
20	SDAT	O	Serial data output for DA converter (IC151)/serial-parallel converter (IC152) ON: "H", OFF: "L"	Connector CN3 ⑩ pin	 Data output in response to 21
21	SCLK	O	Serial clock output for DA converter (IC151)/serial-parallel converter (IC152) ON: "H", OFF: "L"	Connector CN3 ⑨ pin	 Pulse signal is emitted only when a mode change occurs.
22	XIN	I	Microcomputer clock OSC terminal	Z702 ① pin terminal	 Oscillator waveform at 6MHz
23	XOUT	O	Microcomputer clock OSC terminal	Z702 ③ pin terminal	 Oscillator waveform at 6MHz
24	GND	—	Microcomputer GND	IC701 ⑭ pin	0V
25	MLAT2	O	Latch output (Deck 2) for mechanism control ON: "H", OFF: "L"	Connector CN2 ⑦ pin	Serial data is sent to: IC801, IC802, and the mechanism driver IC. Select the Deck 2 data from this serial data and load it into IC802.
26	MLAT1	O	Latch output (Deck 1) for mechanism control ON: "H", OFF: "L"	Connector CN1 ⑥ pin	Select the Deck 1 data from the serial data and load it into IC801.
27	MDAT	O	Serial data output for mechanism control ON: "H", OFF: "L"	Connector CN1 ⑤ pin CN2 ⑥ pin	Serial data used to control the mechanism driver via IC801 and IC802.
28	MCLK	O	Serial clock output for mechanism control ON: "H", OFF: "L"	Connector CN1 ④ pin CN2 ⑤ pin	Emitted only when mechanism mode changes.
29 } 45	P1 } P17	O	FL meter segment output ON: "H", OFF: "L"	FL701 ⑫~⑲ pin	 About 0.5ms About 4ms +5V -20V
46 } 52	1G } 7G	O	FL meter glid output ON: "H", OFF: "L"	FL701 ⑩~⑪ pin	 +5V -20V H for 0~8 pulses of duration approx. 0.5ms each.

Pin No.	Mark
53	RPT1
54	RPS1
55	RPT2
56	RPS2
57	V <sub>DD</sub>
58	-V <sub>P</sub>
59	AV <sub>SS</sub>
60	V <sub>REF</sub>
61	KEY1
62	KEY2
63	MODEL2
64	AD1D1

Pin No.	Mark	I/O Division	Function	Check point	※ Description
18	POF	I	Power off det. input ON: "H", OFF: "L"	Connector CN3 ⑫ pin	 <p>Rectified waveform at both 50 and 60Hz (clamping at 5V)</p> <p>The microprocessor goes into standby mode when this signal is removed.</p>
19	RESET	I	Reset input ON: "L", OFF: "H"	IC701 ⑨ pin	 <p>Usually H (=5V) but L for a period of a few to a few tens of milliseconds is first plugged in when the player.</p>
20	SDAT	O	Serial data output for DA converter (IC151)/serial-parallel converter (IC152) ON: "H", OFF: "L"	Connector CN3 ⑩ pin	 <p>Data output in response to 21</p>
21	SCLK	O	Serial clock output for DA converter (IC151)/serial-parallel converter (IC152) ON: "H", OFF: "L"	Connector CN3 ⑨ pin	 <p>Pulse signal is emitted only when a mode change occurs.</p>
22	XIN	I	Microcomputer clock OSC terminal	Z702 ① pin terminal	 <p>Oscillator waveform at 6MHz</p>
23	XOUT	O	Microcomputer clock OSC terminal	Z702 ⑤ pin terminal	 <p>Oscillator waveform at 6MHz</p>
24	GND	—	Microcomputer GND	IC701 ⑭ pin	0V
25	MLAT2	O	Latch output (Deck 2) for mechanism control ON: "H", OFF: "L"	Connector CN2 ⑦ pin	Serial data is sent to: IC801, IC802, and the mechanism driver IC. Select the Deck 2 data from this serial data and load it into IC802.
26	MLAT1	O	Latch output (Deck 1) for mechanism control ON: "H", OFF: "L"	Connector CN1 ⑥ pin	Select the Deck 1 data from the serial data and load it into IC801.
27	MDAT	O	Serial data output for mechanism control ON: "H", OFF: "L"	Connector CN1 ⑤ pin CN2 ⑥ pin	Serial data used to control the mechanism driver via IC801 and IC802.
28	MCLK	O	Serial clock output for mechanism control ON: "H", OFF: "L"	Connector CN1 ④ pin CN2 ⑤ pin	Emitted only when mechanism mode changes.
29 45	P1 P17	O	FL meter segment output ON: "H", OFF: "L"	FL701 ⑫~⑭ pin	 <p>About 0.5ms About 4ms</p>
46 52	1G 7G	O	FL meter glid output ON: "H", OFF: "L"	FL701 ⑤~⑩ pin	 <p>H for 0~8 pulses of duration approx. 0.5ms each.</p>

Pin No.	Mark	I/O Division	Function	Check point	※ Description
53	RPT1	I	Deck 1 reel pulse det. input (take up side)	TRANSISTOR Q703 collector	 <p>Changes within the 0 ↔ 5V range each time the take up reel on deck 1 is through approximately 30 degrees.</p>
54	RPS1	I	Deck 1 reel pulse det. input (supply side)	TRANSISTOR Q704 collector	 <p>Supply reel on deck 1 Fast FF/REW mode is disabled unless both signals 53 and 54 are active.</p>
55	RPT2	I	Deck 2 reel pulse det. input (take up side)	TRANSISTOR Q705 collector	 <p>Take up reel on deck 2</p>
56	RPS2	I	Deck 2 reel pulse det. input (supply side)	TRANSISTOR Q706 collector	 <p>Supply reel on deck 2 Fast FF/REW mode is disabled unless both signals 55 and 56 are active.</p>
57	V <sub>DD</sub>	—	Microcomputer terminal	Connector CN3 ⑮ pin	+5V, Backup
58	-VP	—	FL meter pull down voltage input terminal	Connector CN3 ⑬ pin	-20V
59	AV <sub>SS</sub>	—	GND terminal (A/D)	Connector CN3 ⑯ pin	0V
60	V <sub>REF</sub>	I	Reference power supply (+5V) (A/D)	Connector CN3 ⑩ pin CN1 ⑧ pin CN2 ⑨ pin	Can be checked at pin 7 of connector CN801 or at pin 9 of CN802.
61	KEY1	I	Key switch input	IC701 ⑩ pin	DECK 1: When no key is pressed: 5V When Stop key is pressed: 0.4V When Power key is pressed: 0V When any other key is pressed: 0 to 5V
62	KEY2	I	Key switch input	IC701 ⑪ pin	DECK 2: When no key is pressed: 5V When Stop key is pressed: 0.4V When any other key is pressed: 0 to 5V
63	MODEL2	I	Model selector terminal	IC701 ⑬ pin	Change the voltage at this pin to match microprocessor operation to the individual model. TR373 (P, PC): 0V TR373 (E, EB, EG, GC, GN): 5V
64	AD1D1	I	Deck 1 Mechanism switch (FINH, CrO <sub>2</sub> , Metal, OPEN/CLOSE) input	Connector CN1 ③ pin	No tape loaded: Approx. 4.1V Normal tape with tab: Approx. 2.3V Chrome tape with tab: Approx. 3.5V Metal tape with tab: Approx. 3.5V

**PRINTED CIRCUIT BOARDS**

A  
B  
C  
D  
E  
F  
G

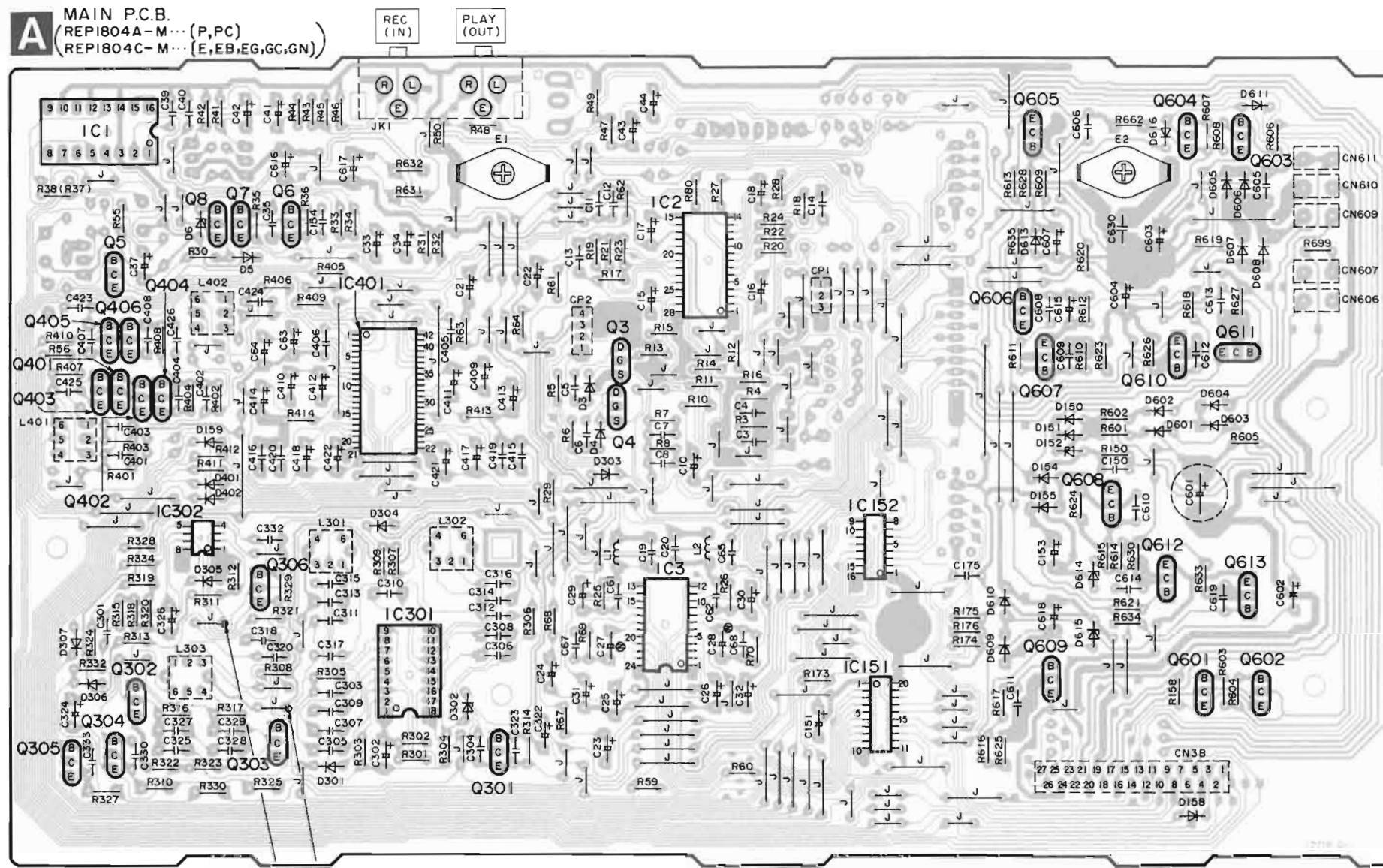

TPI GND  
 ERASE CURRENT CHECK POINT

**D POWER SUPPLY P.C.B. For (Gc) area. (REP1806D-P)**

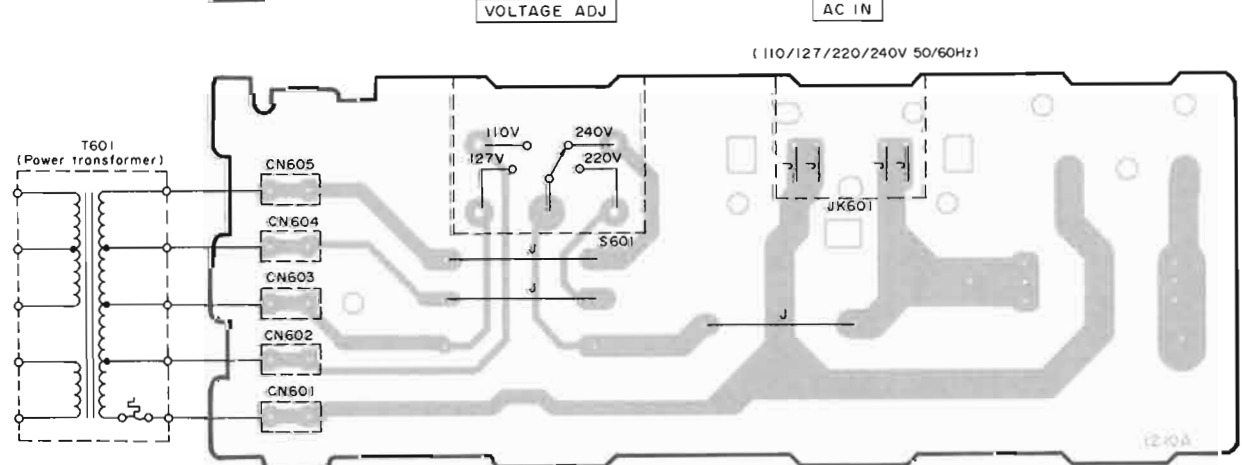

**D POWER SUPPLY P.C.B. For (P,PC,E,EB,EG,GN) areas.**

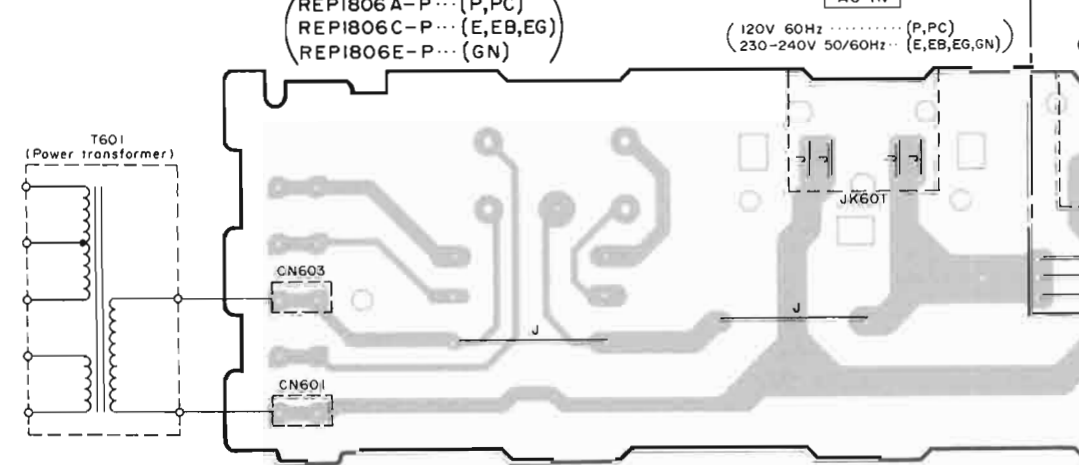

**B MOTOR P.C.B. (DECK I) (REP1807A-T)**

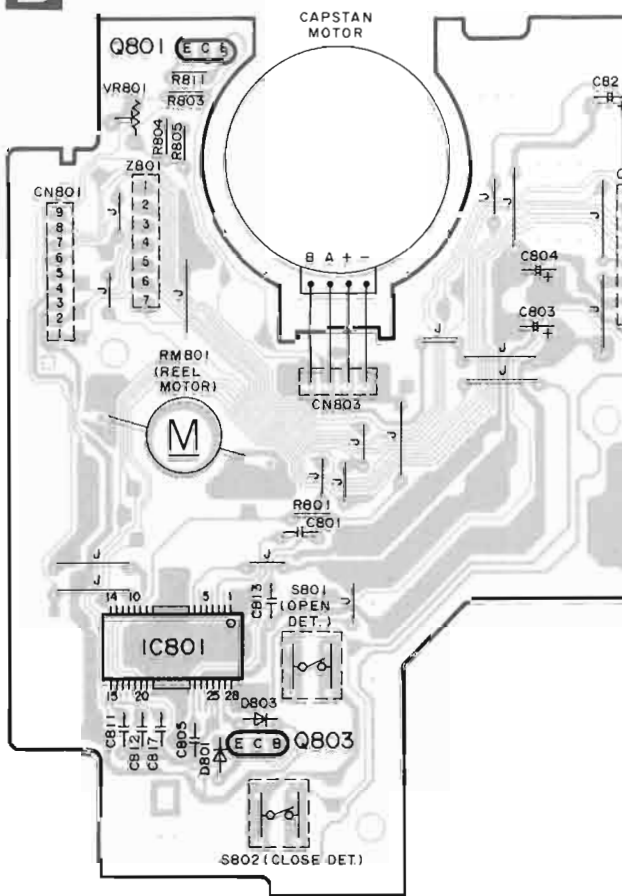



TOR P.C.B. (DECK 1) (REP1807A-T)

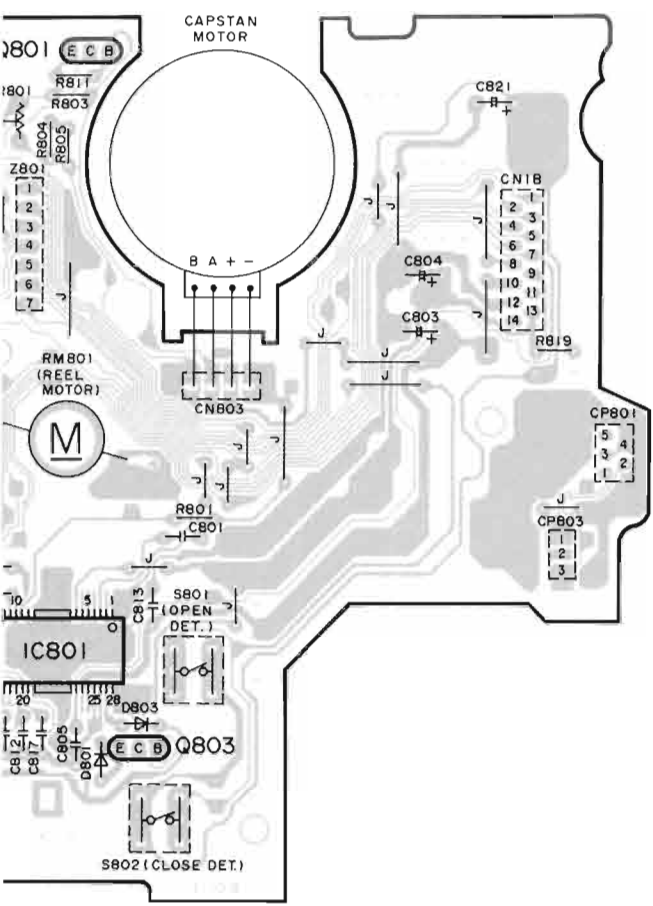

C MOTOR P.C.B. (DECK 2) (REP1808A-T)

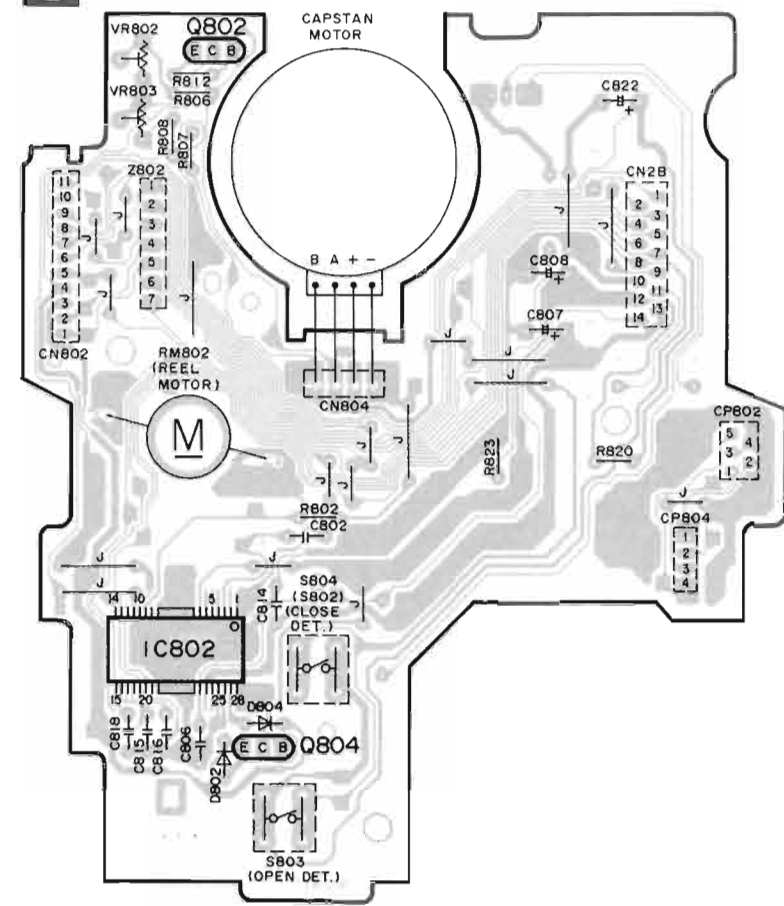

Notes:

- In this printed circuit board diagram, the parts and foil patterns on the board facing toward you are printed in black. The opposite side is printed in blue.
- The "•" mark denote the connection points of double-faced foil patterns (through holes) on both sides of the printed circuit board.
- The resistors enclosed in red boxes in the PCB drawings are printed resistors.
- This printed circuit board diagram may be modified at any time with the development of new technology.

G OPERATION P.C.B. (REP1805A-S... (P,PC) REP1805D-S... (E,EB,EG,GC,GN))

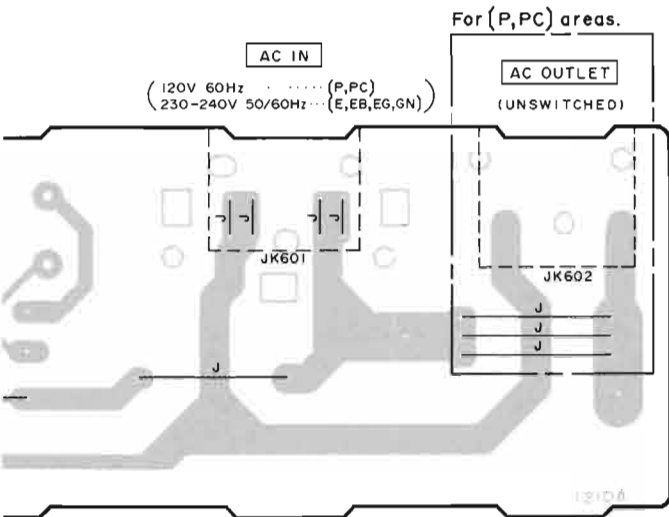
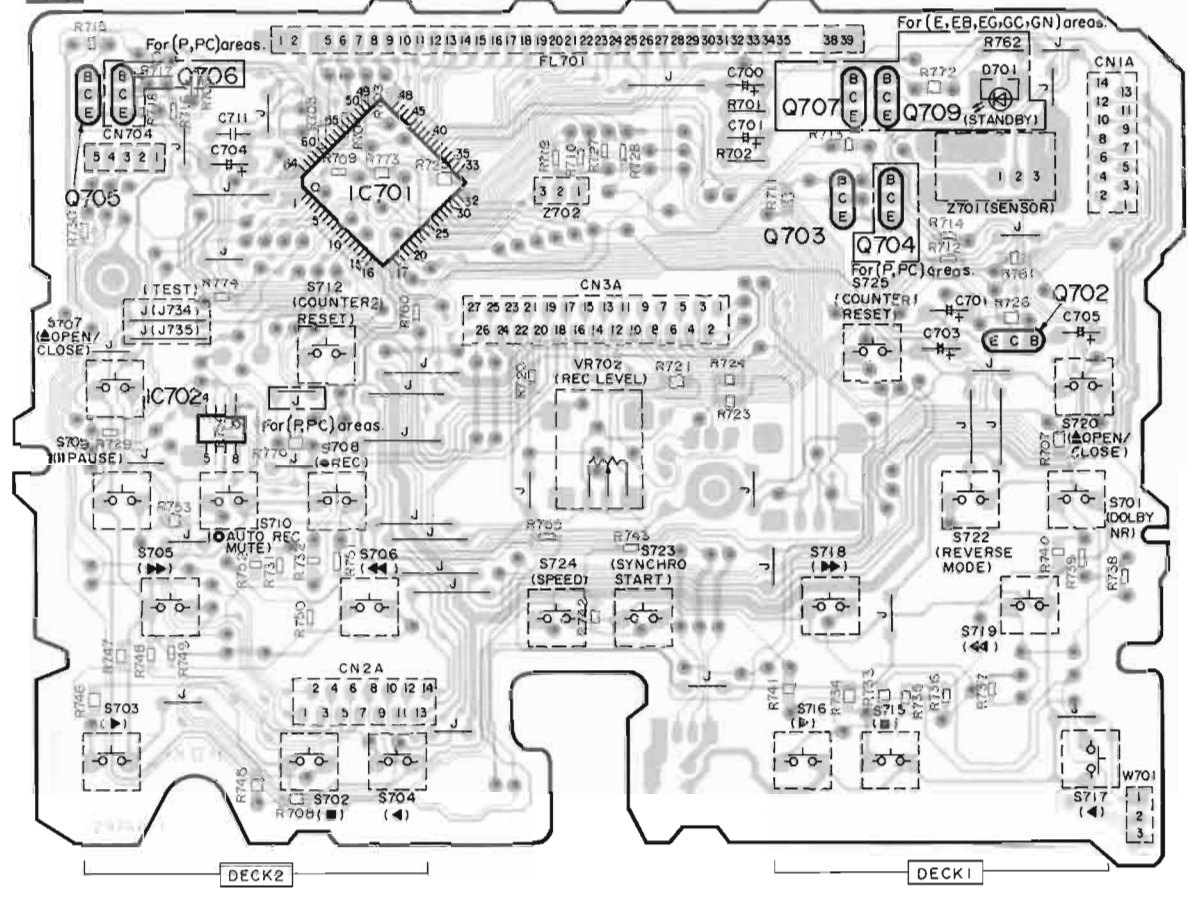

E MECHANISM P.C.B. (DECK 1) (REP1655A)

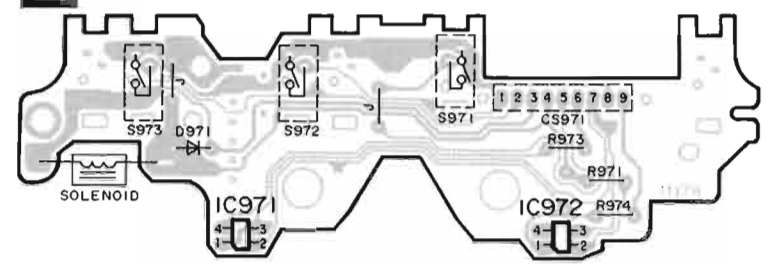

F MECHANISM P.C.B. (DECK 2) (REP1656A)

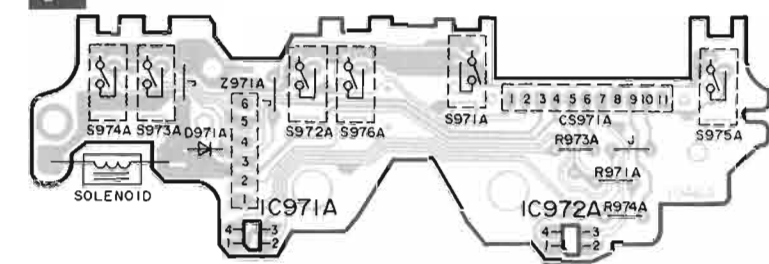

H POWER SWITCH P.C.B. (REP1805A-S... (P,PC) REP1805D-S... (E,EB,EG,GC,GN))

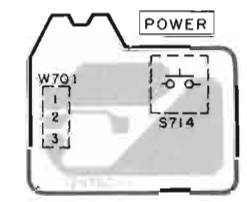



A MAIN CIRCUIT (PLAYBACK EQ AMP/POWER SUPPLY/DOLBY NR/HX PRO/BIAS OSC/REC EQ AMP/CONTROL/ELECTRIC VOLUME)

A  
B  
C  
D  
E  
F  
G

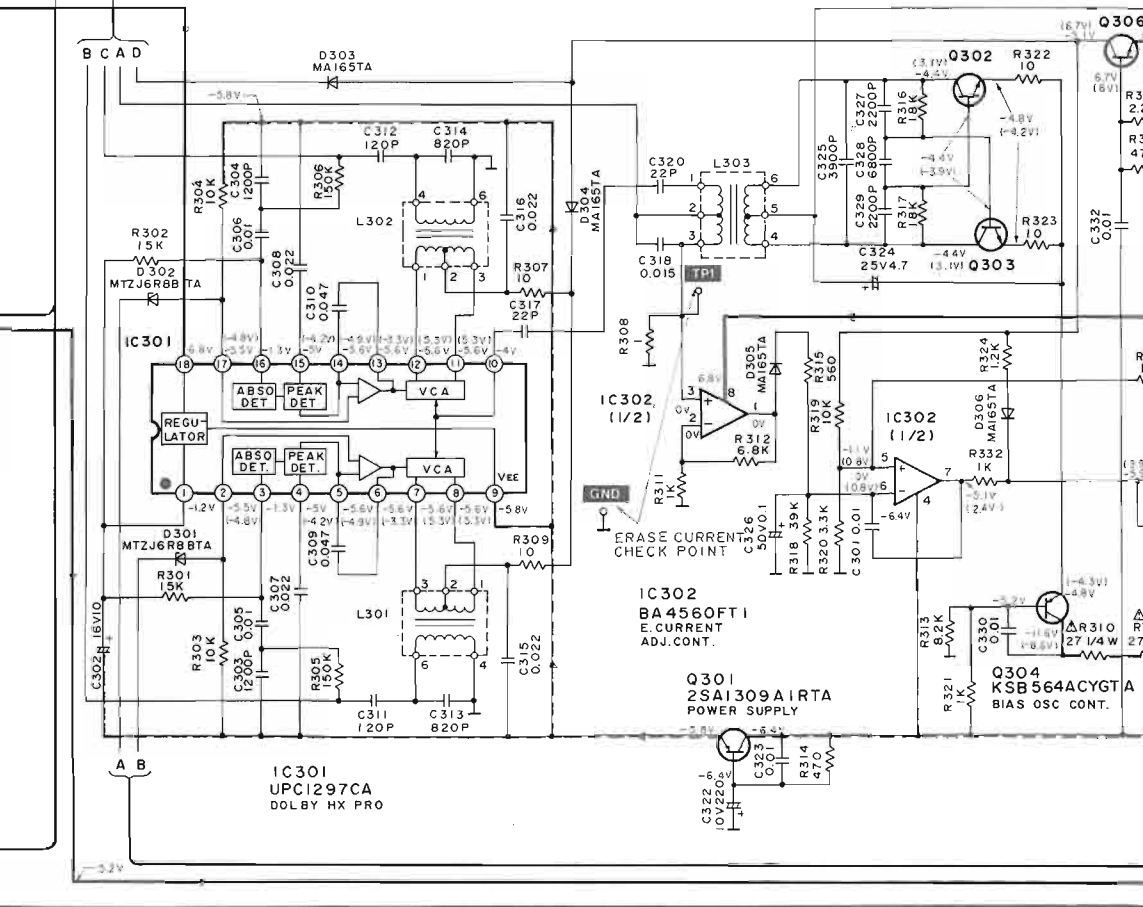
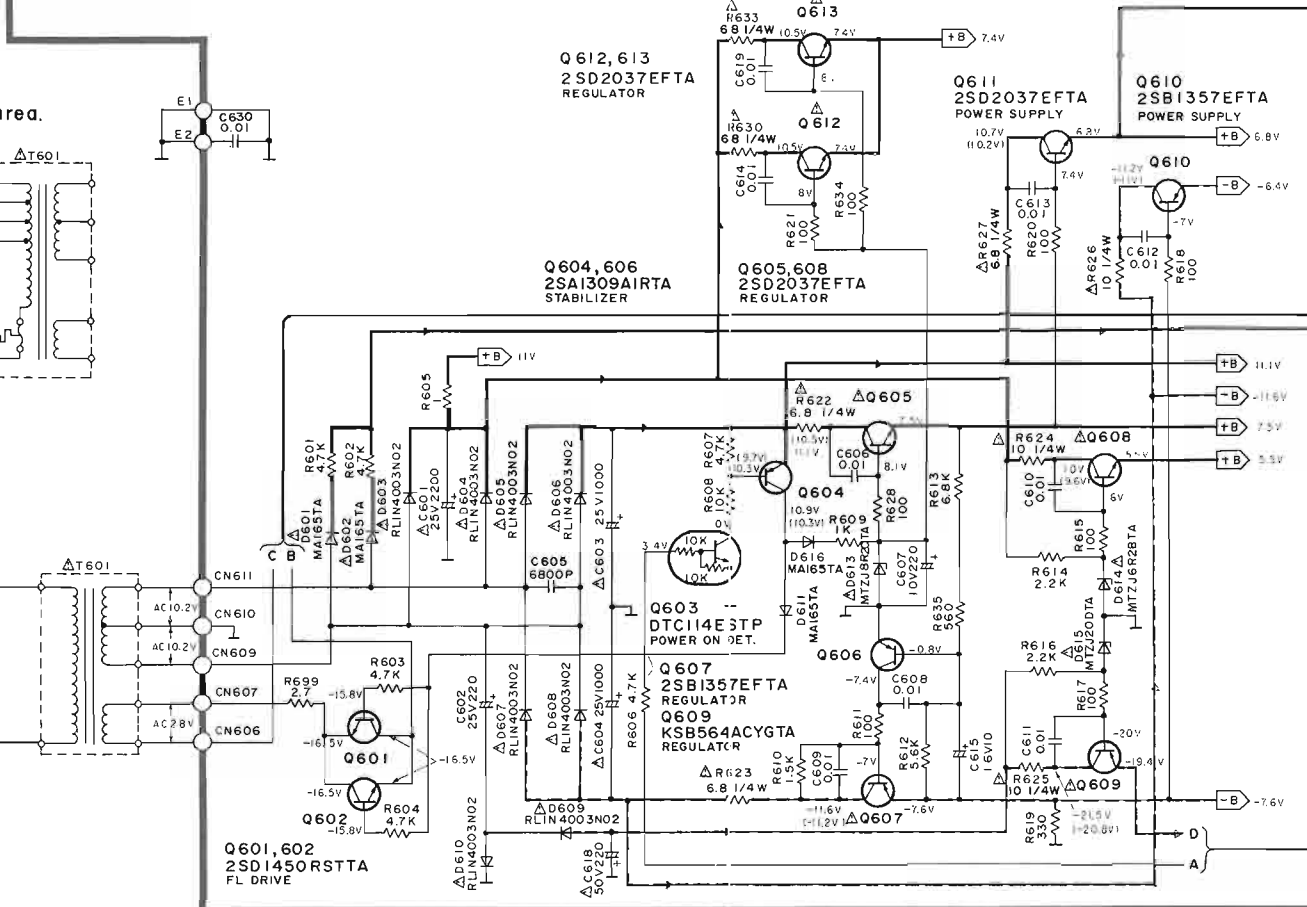
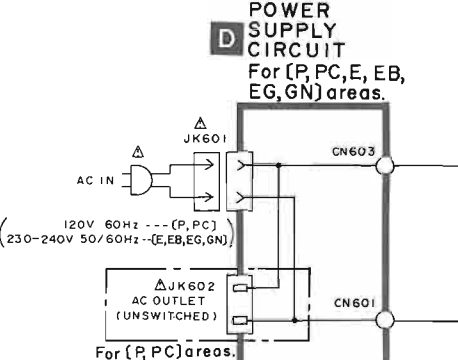
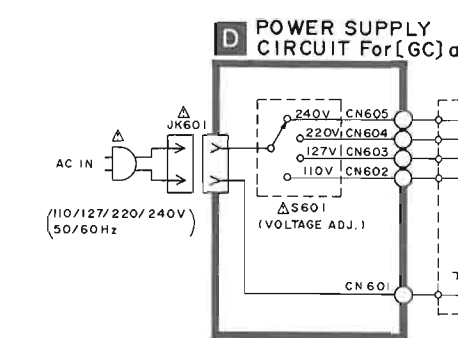
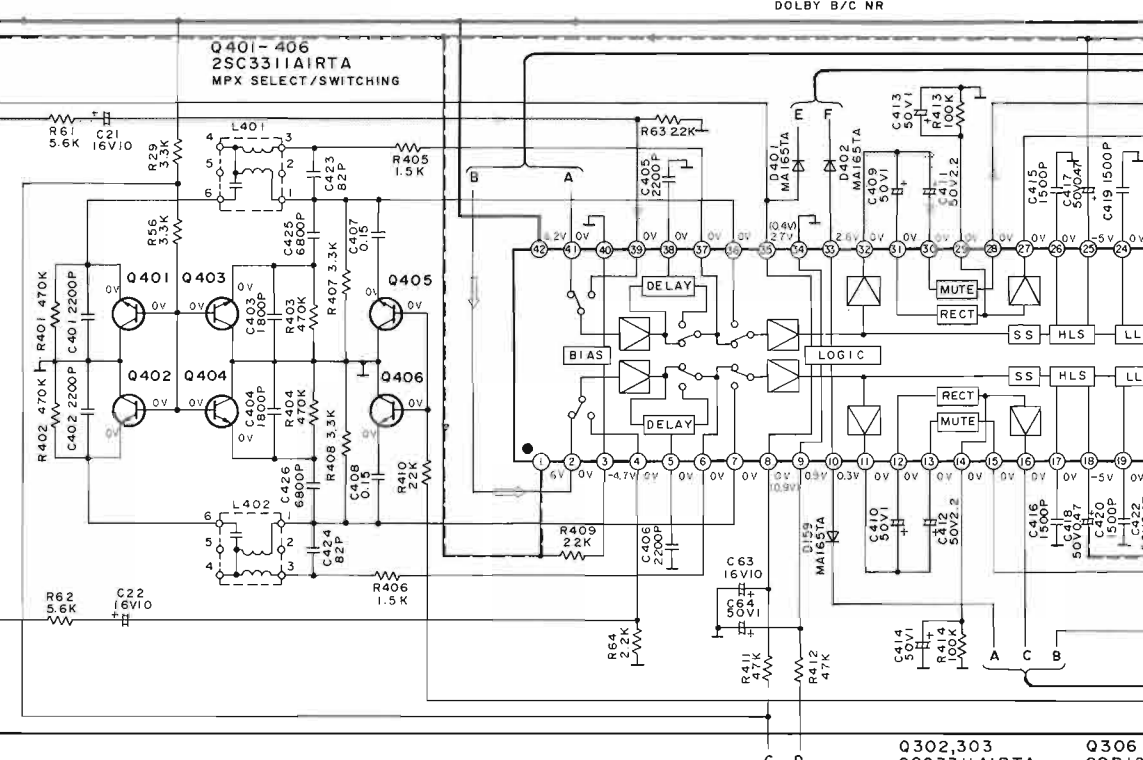
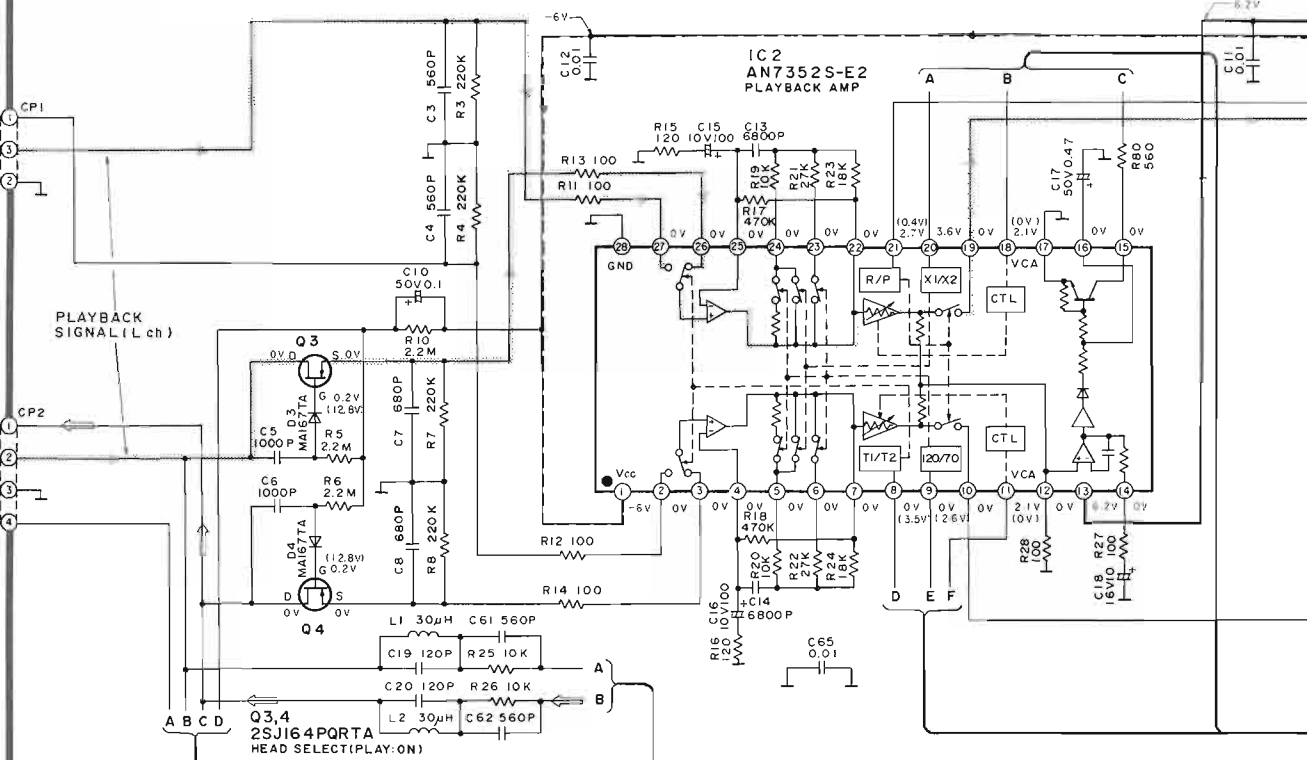
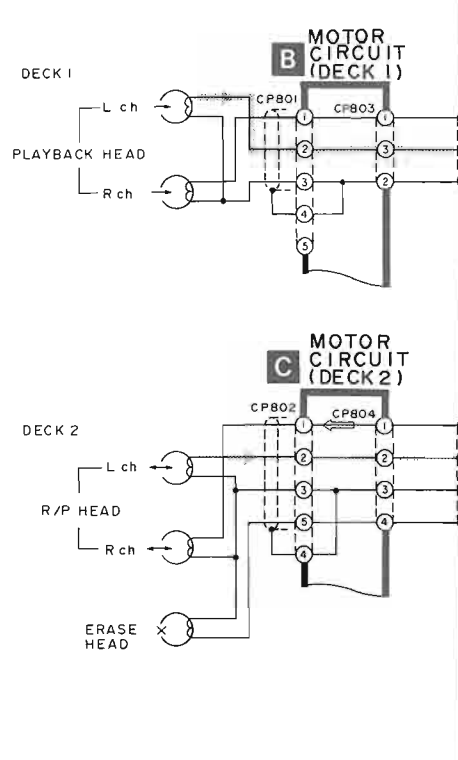

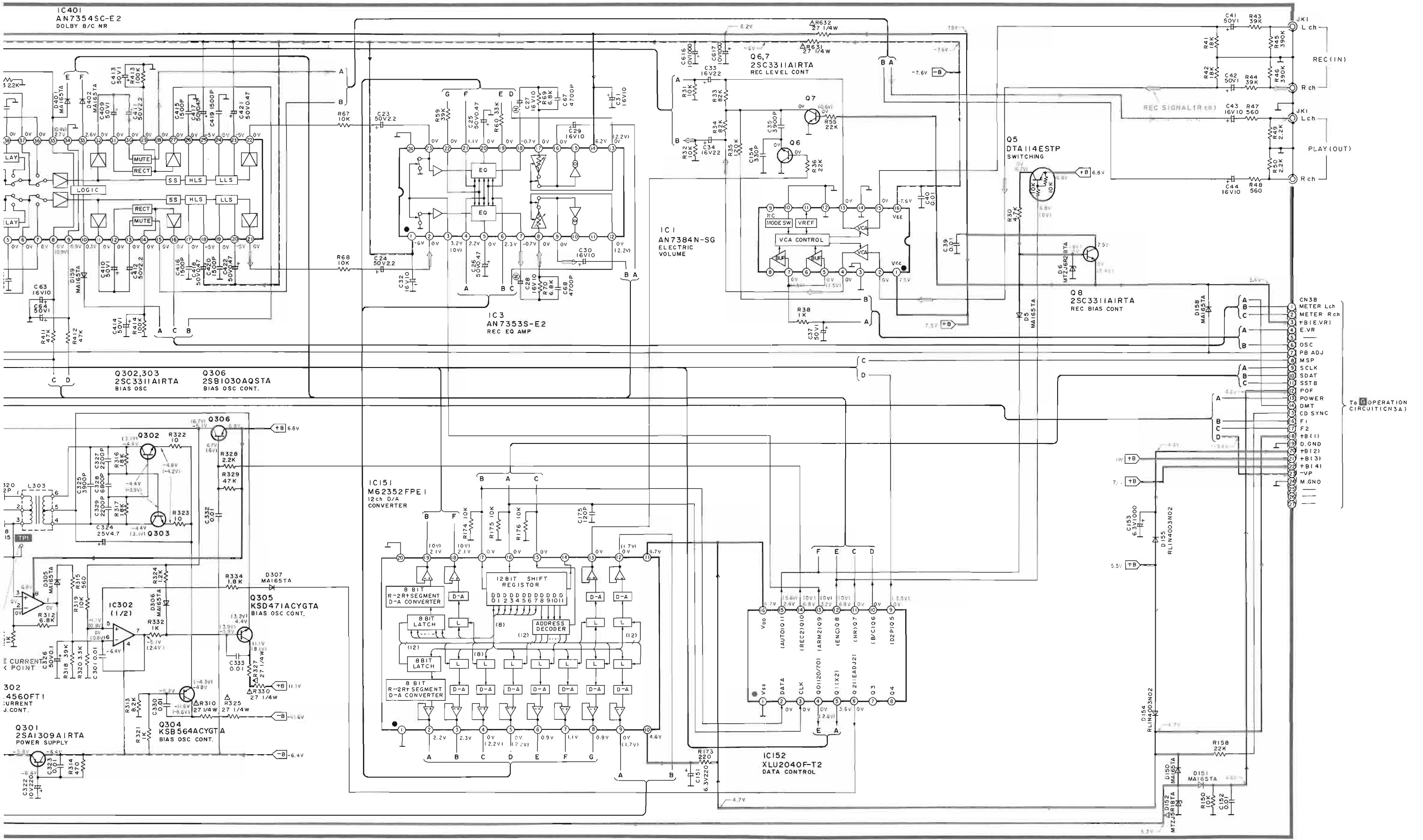

**E MECHANISM CIRCUIT (DECK 1)**

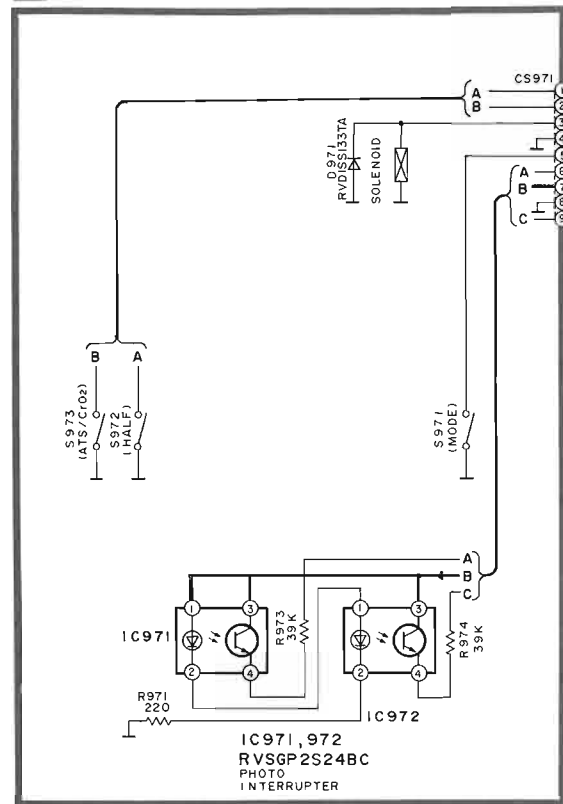

**B MOTOR CIRCUIT (DECK 1)**

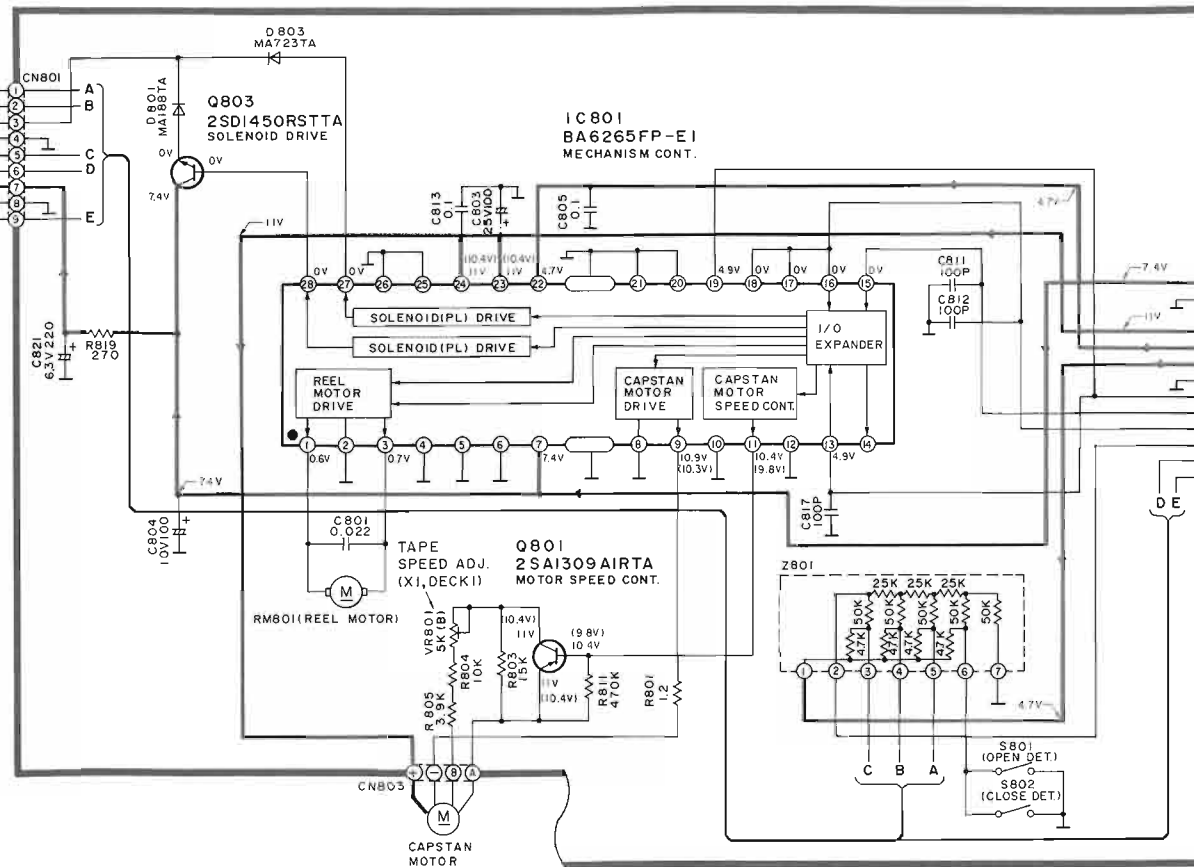

**G OPERATION CIRCUIT**

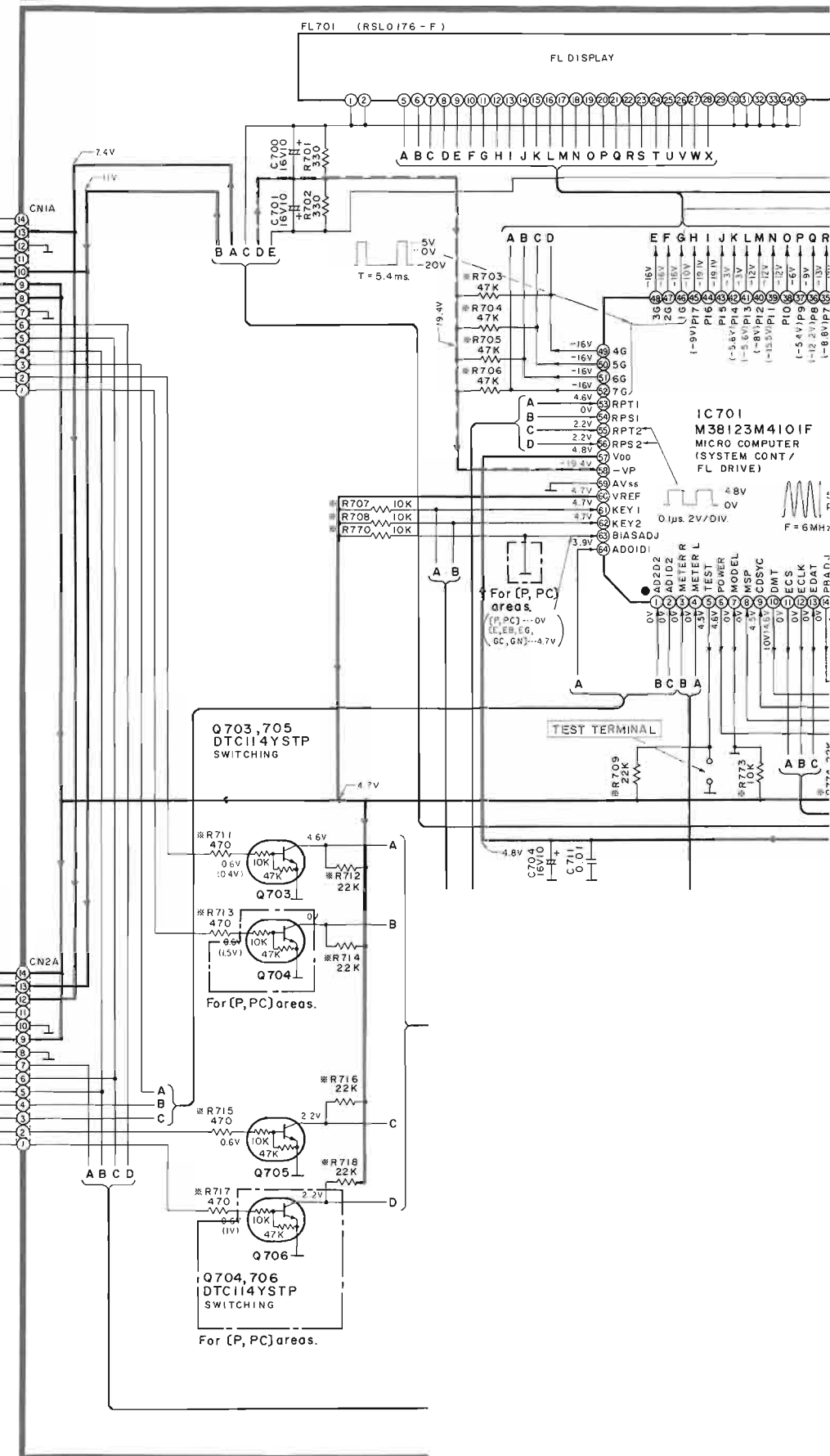

**F MECHANISM CIRCUIT (DECK 2)**

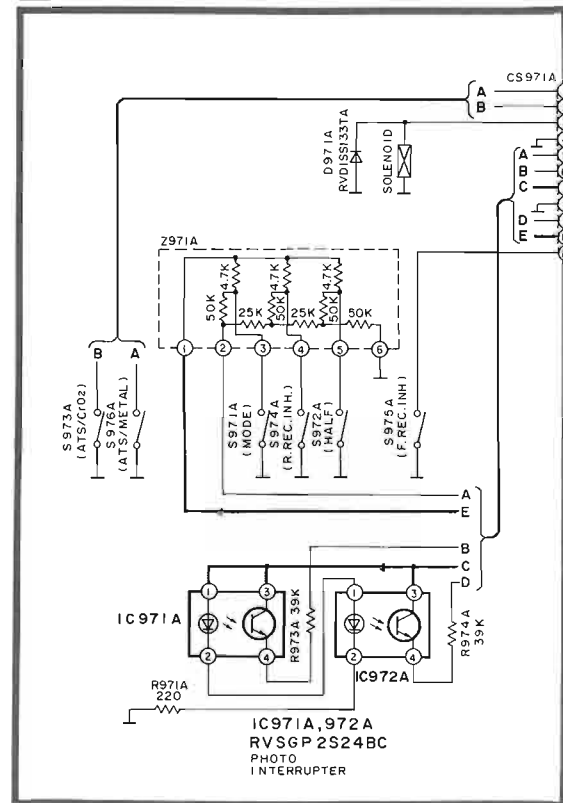

**C MOTOR CIRCUIT (DECK 2)**

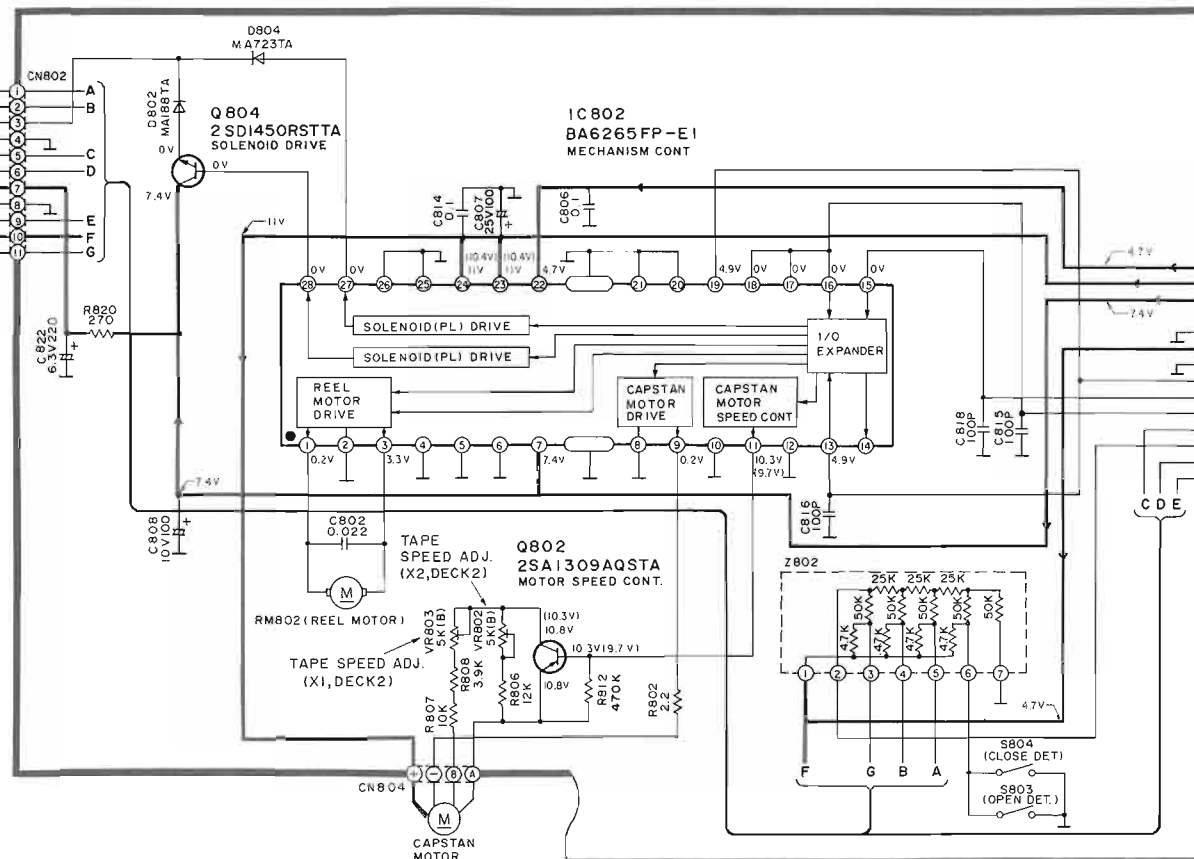

**SCHEMATIC DIAGRAM** (Parts list on pages 57~60.)

(This schematic diagram may be modified at any time with the development of new technology.)

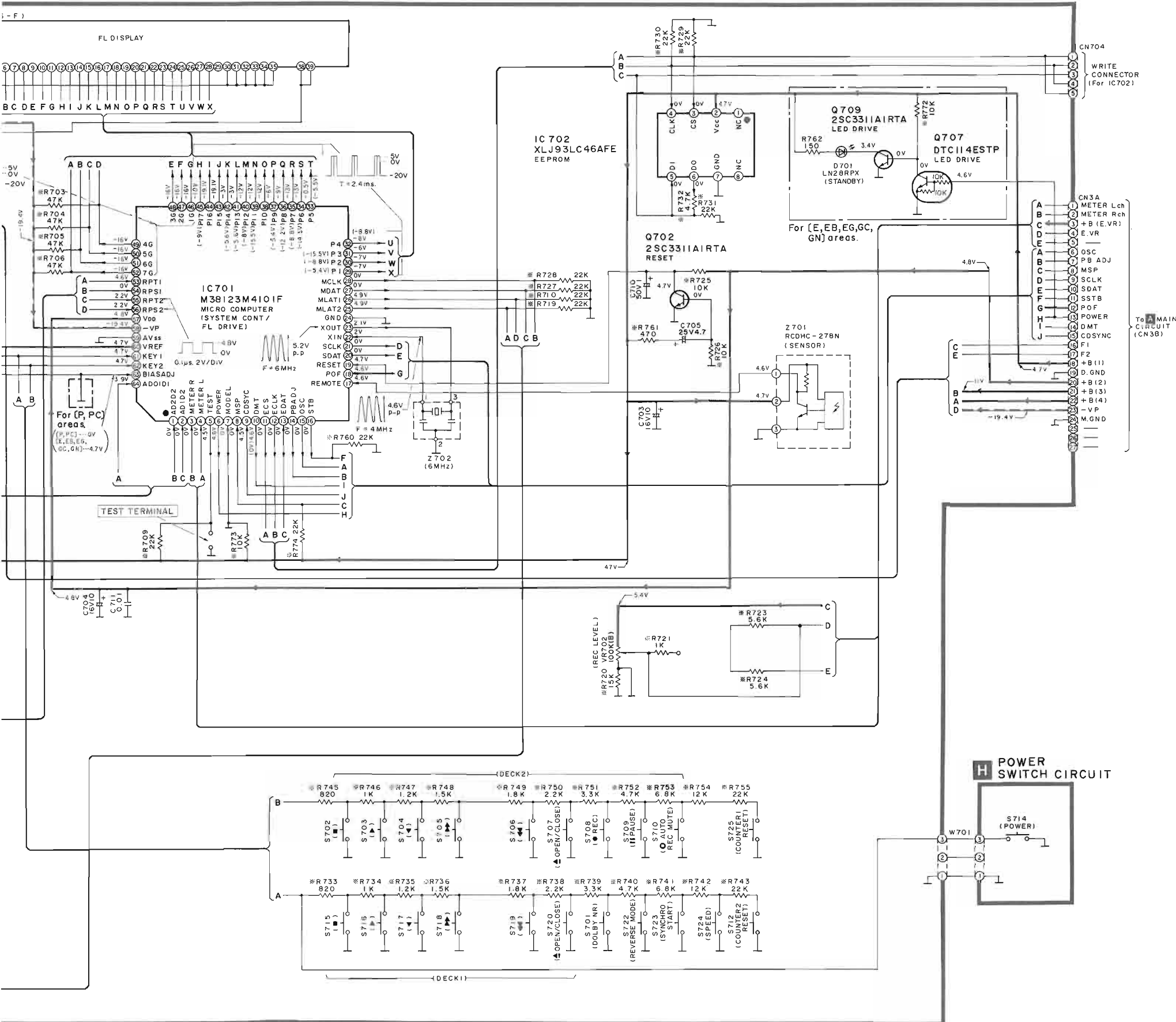

**Note 1:**

- S601 : Voltage selector in "240V" position. (For [GC] area only.) (110V ↔ 127V ↔ 220V ↔ 240V)
- S701 : Dolby noise-reduction switch (DOLBY NR;  $\square$ ,  $\square$ ).
- S702 : DECK 2 Stop switch ( $\blacksquare$ ).
- S703 : DECK 2 Forward-side playback switch ( $\blacktriangleright$ ).
- S704 : DECK 2 Reverse-side playback switch ( $\blacktriangleleft$ ).
- S705 : DECK 2 Fast-forward search switch ( $\blacktriangleright\blacktriangleright$  TPS).
- S706 : DECK 2 Rewind search switch ( $\blacktriangleleft\blacktriangleleft$  TPS).
- S707 : DECK 2 Open/close switch ( $\blacktriangle$  OPEN/CLOSE).
- S708 : DECK 2 Record switch ( $\bullet$  REC).
- S709 : DECK 2 Pause switch ( $\blacksquare$  PAUSE).
- S710 : DECK 2 Automatic-record-muting switch ( $\circ$  AUTO REC MUTE).
- S712 : DECK 2 Counter reset switch (COUNTER 2 RESET).
- S714 : Power "STANDBY  $\phi$  /ON" switch (POWER, STANDBY  $\phi$  /ON).
- S715 : DECK 1 Stop switch ( $\blacksquare$ ).
- S716 : DECK 1 Forward-side playback switch ( $\blacktriangleright$ ).
- S717 : DECK 1 Reverse-side playback switch ( $\blacktriangleleft$ ).
- S718 : DECK 1 Fast-forward search switch ( $\blacktriangleright\blacktriangleright$  TPS).
- S719 : DECK 1 Rewind search switch ( $\blacktriangleleft\blacktriangleleft$  TPS).
- S720 : DECK 1 Open/close switch ( $\blacktriangle$  OPEN/CLOSE).
- S721 : Auto tape calibration switch (ATC).
- S722 : Reverse-mode select switch (REVERSE MODE).
- S723 : Synchro-start switch (SYNCHRO START).
- S724 : Tape-to-tape recording-speed switch (SPEED; X1, X2).
- S725 : DECK 1 Counter reset switch (COUNTER 1 RESET)
- S801 : DECK 1 Cassette holder open detection switch in "off" position.
- S802 : DECK 1 Cassette holder close detection switch in "off" position.
- S803 : DECK 2 Cassette holder open detection switch in "off" position.
- S804 : DECK 2 Cassette holder close detection switch in "off" position.
- S971 : DECK 1 Mode switch in "off" position.
- S971A : DECK 2 Mode switch in "off" position.
- S972 : DECK 1 Half switch in "off" position.
- S972A : DECK 2 Half switch in "off" position.
- S973 : DECK 1 ATS (CrO<sub>2</sub>) switch in "off" position.
- S973A : DECK 2 ATS (CrO<sub>2</sub>) switch in "off" position.
- S974A : DECK 2 Reverse rec. inhibit switch in "off" position.
- S975A : DECK 2 Forward rec. inhibit switch in "off" position.
- S976A : DECK 2 ATS (Metal) switch in "off" position.
- Resistance are in ohms ( $\Omega$ ), 1/4 watt unless specified otherwise. 1K=1,000 ( $\Omega$ ), 1M=1,000k ( $\Omega$ )
- Capacity are in micro-farads ( $\mu$ F) unless specified otherwise.
- All voltage values shown in circuitry are under no signal condition and playback mode with volume control at minimum position otherwise specified. ( )..... Voltage values at record mode.

For measurement us EVM.  
**Important safety notice**  
 Components identified by  $\Delta$  mark have special characteristics important for safety.  
 When replacing any of these components, use only manufacturer's specified parts.  
 • (  $\leftarrow$  +B  $\rightarrow$  ) indicates +B (bias).  
 • (  $\leftarrow$  -B  $\rightarrow$  ) indicates -B (bias).  
 • (  $\leftarrow$  ) indicates the flow of the playback signal.  
 • (  $\rightarrow$  ) indicates the flow of the record signal.  
 • The supply part number is described alone in the replacement parts list,

Ref. No.	Production Part No.	Supply Part No.
IC152	XLU2040F-T2	XLU2040F-T1
IC302	BA4560FT1	SVIBA4560FT1

※ marks indicate printed resistor.



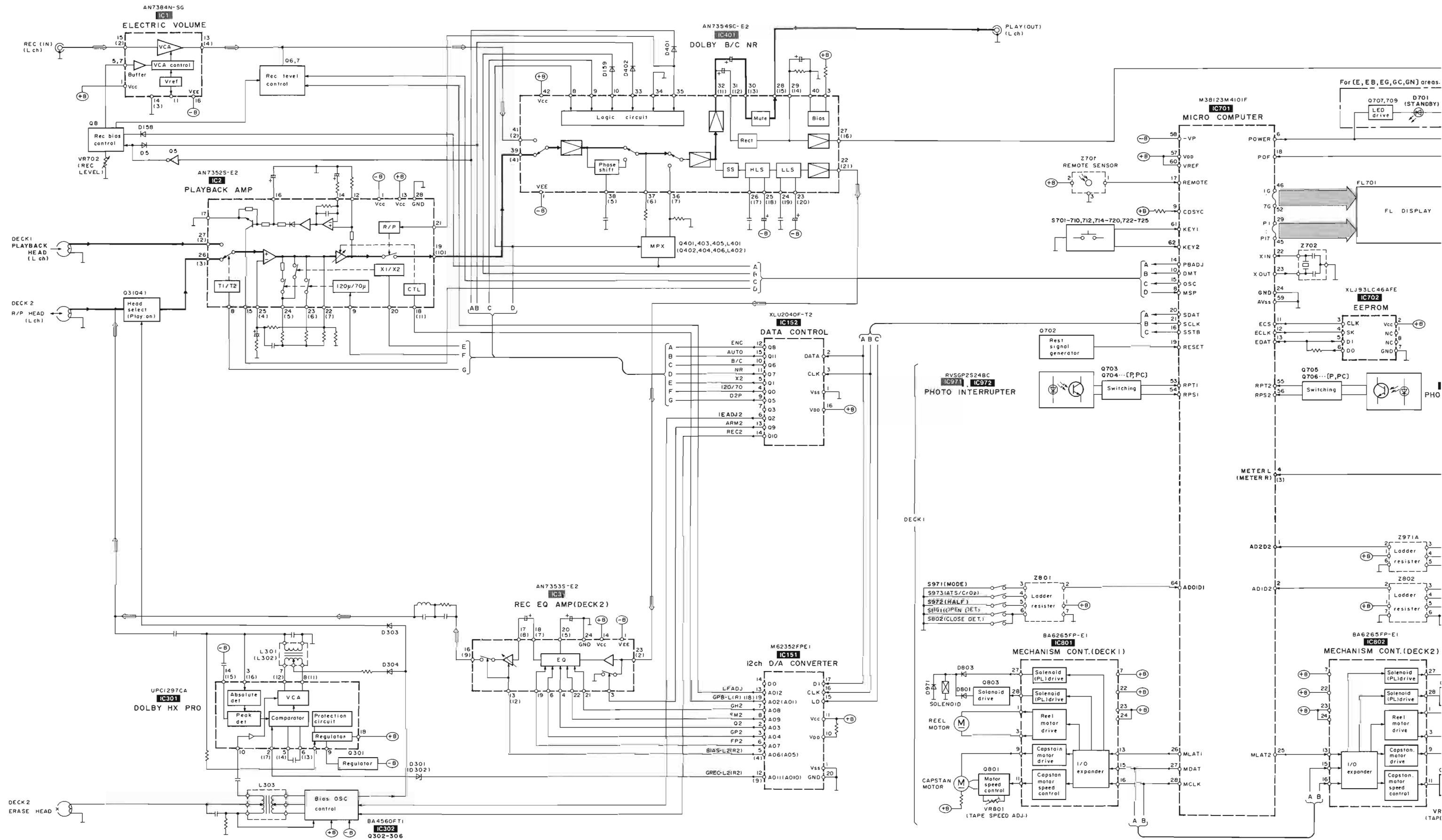

**Caution!**

- IC and LSI are sensitive to static electricity.
- Secondary trouble can be prevented by taking care during repair.
- Cover the parts boxes made of plastics with aluminum foil.
- Ground the soldering iron.
- Put a conductive mat on the work table.
- Do not touch the legs of IC or LSI with the fingers directly.

BLOCK DIAGRAM

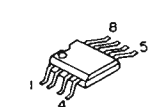
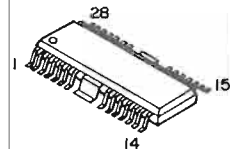

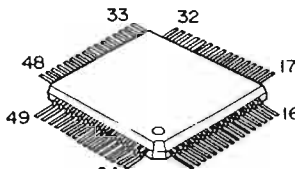
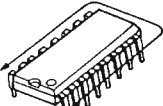
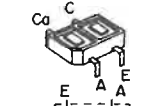
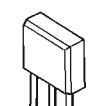
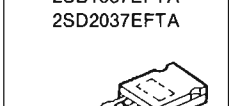
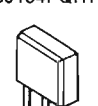
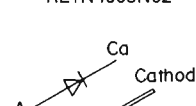
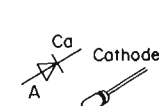
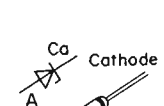
■ TERMINAL GUIDE OF IC'S, TRANSISTORS AND DIODES

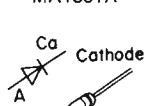
 BA4560FT1	 BA6265FP-E1	 No.1 XLJ93LC46AFE 8 Pin XLU2040F-T2 16 Pin M62352FPE1 20 Pin AN7353S-E2 24 Pin AN7352S-E2 28 Pin AN7354SC-E2 42 Pin	 M38123M4101F
 No.1 AN7384N-SG 16 Pin UPC1297CA 18 Pin	 No.1 RVSGP2S24BC	DTA114ESTP DTC114ESTP DTC114YSTP	KSB564ACYGTA KSD471ACYGTA
 2SA1309AIRTA 2SB1030AQSTA 2SC3311AIRTA 2SD1450RSTTA	 2SB1357EFTA 2SD2037EFTA	 2SJ164PQRTA	 RL1N4003N02 Cathode Anode
 MA165TA MA167TA MA723TA RVD1SS133TA	 MTZJ5R1BTA MTZJ6R2BTA MTZJ6R8BTA MTZJ8R2CTA MTZJ20DTA	 LN28RPX Anode Cathode	 MA188TA Cathode Anode

Notes  
 1) ( ) indicates pin No. of right channel.  
 2)

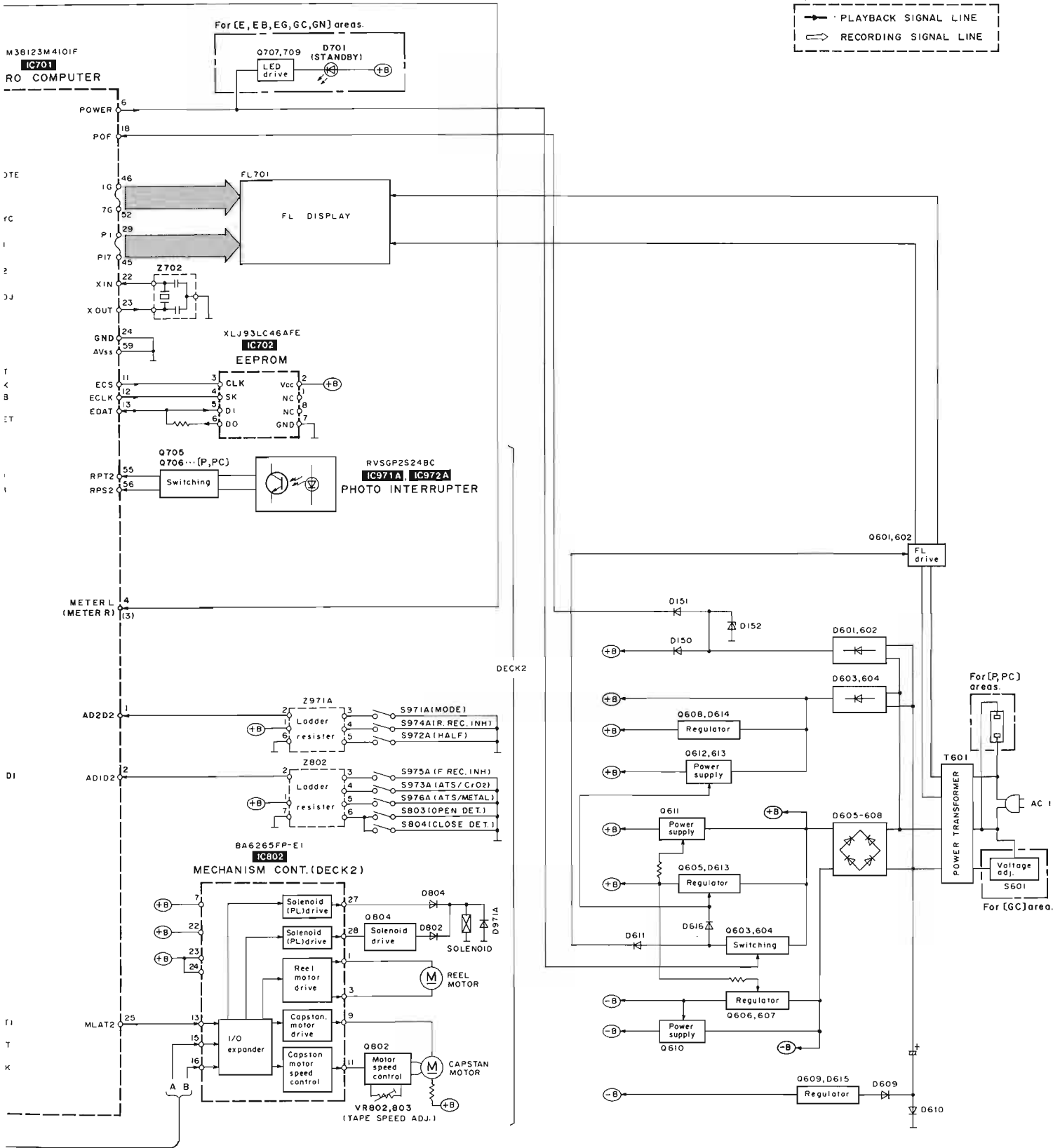
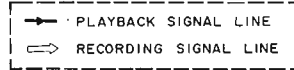

■ PACKAGING

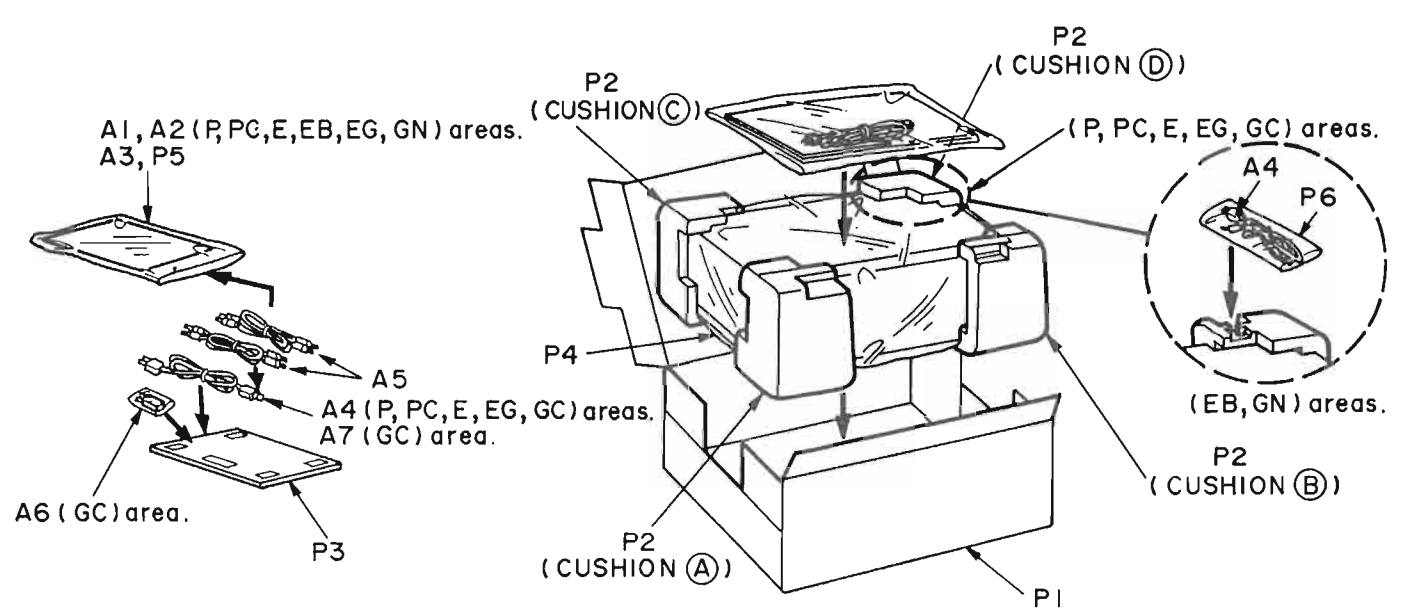

<CUSHION (A), (B), (C), (D) Part No.: RPN0664-1 (P, PC, E, EG, GC), RPN0665 (EB, GN)>



# CABINET PARTS LOCATION

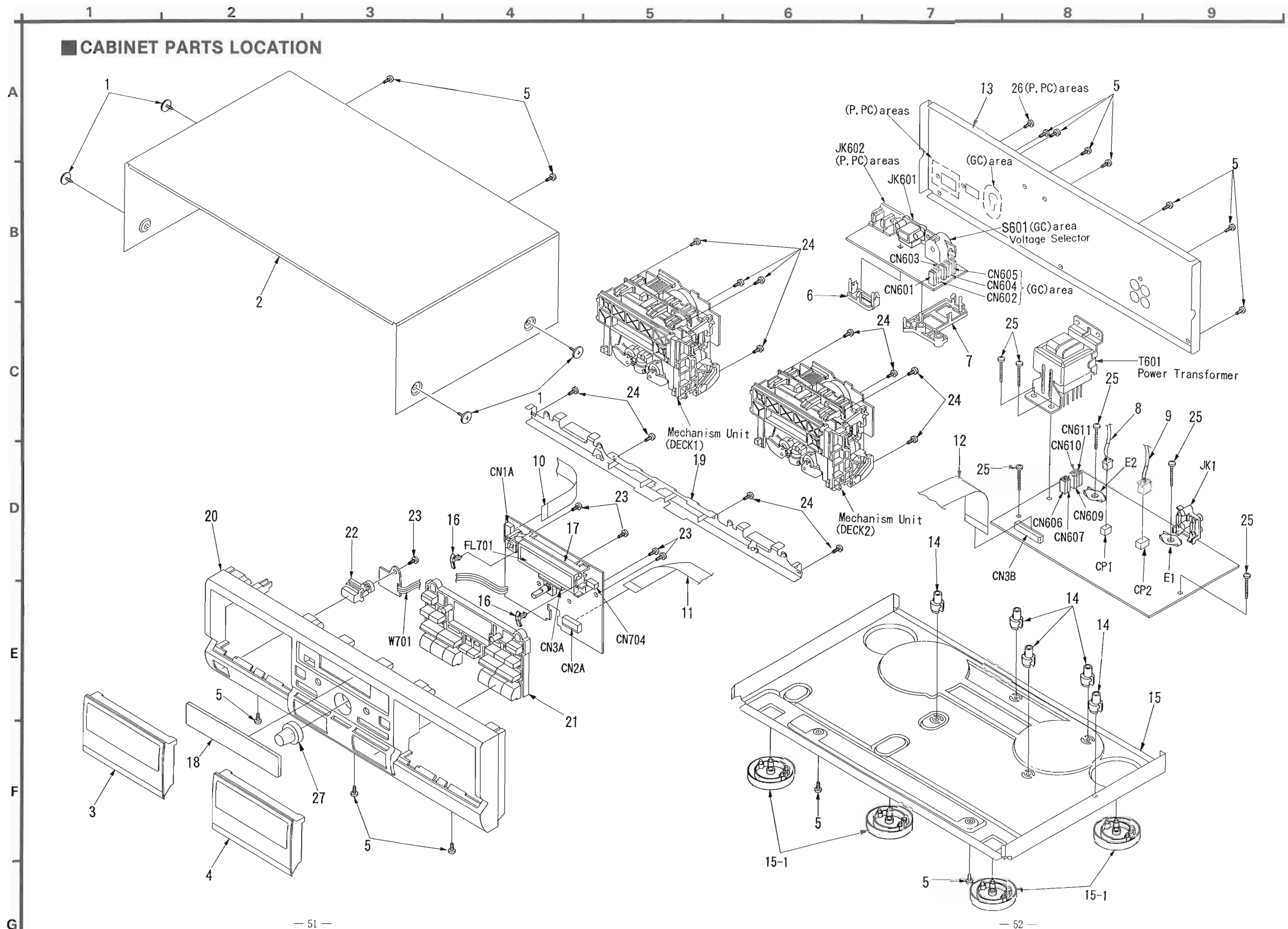

REPLACEMENT PARTS	
Ref. No.	Part No.
1	RF
2	RF
3	RY
3	RY
4	RY
4	RY
5	XT
6	RF
7	RF
8	RF
9	RF
10	RF
11	RF
12	RF
13	RF
13	RF
13	RF
14	RF
15	RF
15-1	RF
16	RF
17	RF
18	RF
18	RF
19	RF
20	RF
21	RF
22	RF
23	XT
24	XT
25	XT
26	XT
27	RF
P1	RF
P1	RF
P1	RF
P1	RF
P2	RF
P2	RF
P3	RF

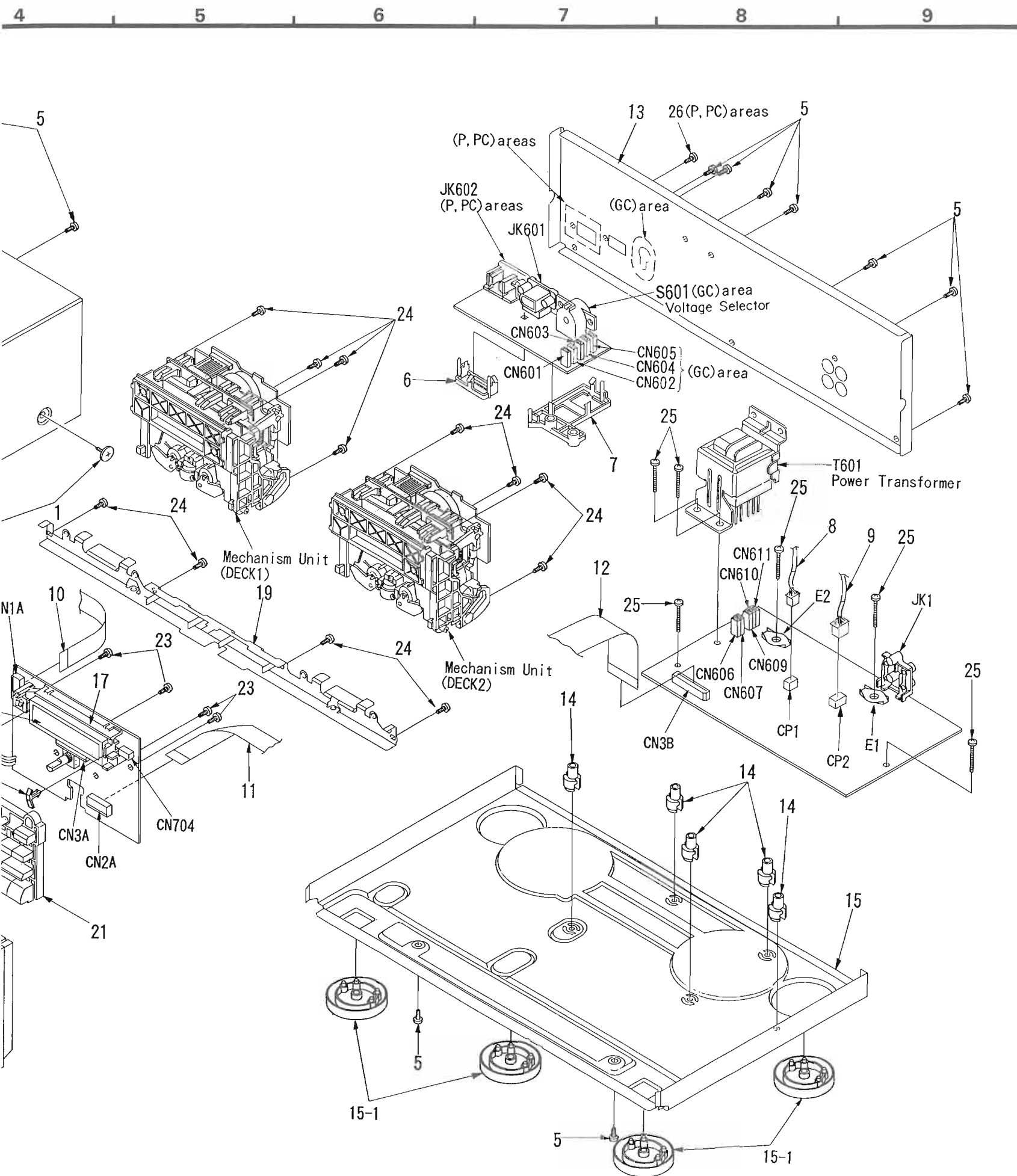

## REPLACEMENT PARTS LIST

**Notes:** \*Important safety notice:  
 Components identified by  $\Delta$  mark have special characteristics important for safety.  
 Furthermore, special parts which have purposes of fire-retardant (resistors), high-quality sound (capacitors), low-noise (resistors), etc. are used.  
 When replacing any of components, be sure to use only manufacturer's specified parts shown in the parts list.  
 \*The parenthesized indications in the Remarks columns specify the areas. (Refer to the cover page for area.)  
 Parts without these indications can be used for all areas.  
 \*The "(SF)" mark denotes the standard part.

Ref. No.	Part No.	Part Name & Description	Remarks	Ref. No.	Part No.	Part Name & Description	Remarks
		CABINET AND CHASSIS		P4	XZB50X65A02Z	PROTECTION COVER (THIS UNIT)	
				P5	XZB24X34C04	PROTECTION BAG (F. B., ACC.)	
				P6	RPH0032	MIRROR SHEET	(EB, GN)
						ACCESSORIES	
1	RHD30035-K	SCREW					
2	RKWO260-K	CABINET					
3	RYFO262A-K	CASSETTE LID (DECK1)	(P, PC)				
3	RYFO262D-K	CASSETTE LID (DECK1)	(E, EB, EG, GC, GN)	A1	RQT2233-P	INSTRUCTION MANUAL	(P)
4	RYFO262B-K	CASSETTE LID (DECK2)	(P, PC)	A1	RQT2237-B	INSTRUCTION MANUAL	(EB, GN)
4	RYFO262J-K	CASSETTE LID (DECK2)	(E, EB, EG, GC, GN)	A1	RFKSSTR373E	INSTRUCTION MANUAL ASS'Y	(E)
5	XTBS3+8JFZ1	SCREW		A1	RFKSSTR373EG	INSTRUCTION MANUAL ASS'Y	(EG)
6	RFKNSTR373AK	TRANSFORMER BASE 1 ASS'Y		A1	RFKSSTR373GC	INSTRUCTION MANUAL ASS'Y	(GC)
7	RFKNSTR373BK	TRANSFORMER BASE 2 ASS'Y		A1	RFKSSTR373PC	INSTRUCTION MANUAL ASS'Y	(PC)
8	REX0578	CONNECTOR ASS'Y (3P)		A2	RQAO013	WARRANTY CARD	(E, EB, EG)
9	REX0579	CONNECTOR ASS'Y (4P)		A2	RQAO085	WARRANTY CARD	(P)
10	REZ0641	FLEXIBLE FLAT CABLE (14P)		A2	RQX7433ZA	WARRANTY CARD	(GN)
11	REZ0642	FLEXIBLE FLAT CABLE (14P)		A2	SQX7183	WARRANTY CARD	(PC)
12	REZ0643	FLEXIBLE FLAT CABLE (27P)		A3	RQCB0169	SERVICENTER LIST	(E, EB, EG, GC, GN)
13	RGRO185A-A	REAR PANEL	(P, PC)	A3	RQCB0391	SERVICENTER LIST	(P)
13	RGRO185B-A1	REAR PANEL	(E, EG)	A3	SQX9131	SERVICENTER LIST	(PC)
13	RGRO185B-C1	REAR PANEL	(EB, GN)	A4	RJAO019-2K	AC POWER SUPPLY CORD	(E, EG, GC) $\Delta$ (SF)
13	RGRO185C-A	REAR PANEL	(GC)	A4	RJAO036-K	AC POWER SUPPLY CORD	(GN) $\Delta$ (SF)
14	RKQO089	P. C. B. HOLDER		A4	SJA172	AC POWER SUPPLY CORD	(P, PC) $\Delta$ (SF)
15	RFKJLPG460-K	BOTTOM CHASSIS ASS'Y		A4	VJA0733	AC POWER SUPPLY CORD	(EB) $\Delta$ (SF)
15-1	RKA0053-A	FOOT		A5	SJP2249-3	STEREO CONNECTION CABLE	
16	RMNO195	FL HOLDER PIECE		A6	SJP5213-1	POWER PLUG ADAPTOR	(GC) $\Delta$
17	RMNO259	FL HOLDER		A7	RQLA0134	CAUTION LABEL (VOL. SELECTOR)	(GC)
18	RKWO326-R	TRANSPARENT PLATE	(P, PC)				
18	RKWO326B-R	TRANSPARENT PLATE	(E, EB, EG, GC, GN)				
19	RMA0766	MECHANISM ANGLE					
20	RFKNGSTR373PK	FRONT PANEL ASS'Y					
21	RFKNSTR373CK	BUTTON ASS'Y, OPERATION					
22	RGU1026-K	BUTTON, POWER					
23	XTBS26+8J	SCREW					
24	XTB3+10JFZ	SCREW					
25	XTB3+20JFZ	SCREW					
26	XTBS3+8JFZ1	SCREW	(P, PC)				
27	RGWO197-K	KNOB, REC LEVEL					
		PACKING MATERIAL					
P1	RPG1908	PACKING CASE	(P, PC, GC)				
P1	RPG1911	PACKING CASE	(E, EG)				
P1	RPG1912	PACKING CASE	(EB)				
P1	RPG2065	PACKING CASE	(GN)				
P2	RPNO664-1	CUSHION	(P, PC, E, EG, GC)				
P2	RPNO665	CUSHION	(EB, GN)				
P3	RPQO164	ACCESSORIES PAD					



Ref. No.	Part No.	Part Name & Description	Remarks
		MECHANISM PARTS	
101	RXF0045	FLYWHEEL (F) ASS'Y (DECK1)	
101	RXF0045	FLYWHEEL (F) ASS'Y (DECK2)	(P, PC)
101	RXF0040	FLYWHEEL (F) ASS'Y (DECK2)	(E, EB, EG, GC, GN)
102	RXF0046	FLYWHEEL (R) ASS'Y (DECK1)	
102	RXF0046	FLYWHEEL (R) ASS'Y (DECK2)	(P, PC)
102	RXF0047	FLYWHEEL (R) ASS'Y (DECK2)	(E, EB, EG, GC, GN)
103	RMLD272	SWITCH LEVER	
104	RXQ0265	HEAD BASE ASS'Y	
104-1	RMB0266-1	SPRING, FOR. /REV. SIDE ROD	
104-2	RXMD036	FOR. /REV. SIDE ROD	
105	RKD0582-K	DRESSING PLATE	
106	RXQ0317	HEAD BLOCK (P. B.) (DECK1)	
106	RXQ0316	HEAD BLOCK (R/P) (DECK2)	
106-1	RHD17015	AZIMUTH ADJUSTMENT SCREW	
106-2	RMB0352	SPRING, HEAD HOLD	
106-3	RMQ0360A	CONNECTOR HOLDER	
107	RDV108ZA	BELT (DECK1)	
107	RDV108ZA	BELT (DECK2)	(P, PC)
107	RDV0015	BELT (DECK2)	(E, EB, EG, GC, GN)
108	RDK0019A	MAIN GEAR	
109	RMB0261	SPRING, HEAD BASE	
110	RMB0262	SPRING, BRAKE ROD	
111	RMB0263	SPRING (F)	
112	RMB0264	SPRING (R)	
113	RJW147ZA	SPRING, TRIGGER LEVER	
114	RMLD267A	TRIGGER LEVER	
115	RMLD268A	FOR. /REV. SIDE LEVER	
116	RMM0091A	BRAKE ROD	
117	RMS0398	MOVING IRON CORE	
118	RSJ0003	SOLENOID	
119	RJS609ZC	SPRING, TAPE PRESSURE	
120	RXG0036	REEL GEAR	
121	RXL0106	IDLER GEAR	
122	RXP0052	PINCH ROLLER (F) ASS'Y	
122-1	RMB0259	SPRING, PINCH ROLLER (F)	
123	RXP0053	PINCH ROLLER (R) ASS'Y	
123-1	RMB0260	SPRING, PINCH ROLLER (R)	
124	RDG0206-1	LOADING GEAR	
125	RDG0209A	INTERMEDIATE GEAR	
126	REM0036-1	CAPSTAN MOTOR	
127	REM0043	REEL MOTOR	
128	RHD26013	SCREW	
129	RMCO169	SHIELD PLATE	
130	RMQ0314A	SURASUTO SPACER	
131	RXG0037	FRICTION GEAR ASS'Y	
132	RYF0263-K	CASSETTE HOLDER ASS'Y	
132-1	RJS757ZA	SPRING, TAPE PRESSURE	
133	RMQ0430	RIVET	
134	RMB0269	SPRING, DRIVE LEVER	

Ref. No.	Part No.	Part Name & Description	Remarks
135	RMLD270A-1	DRIVE LEVER	
136	RMQ0312A	DRIVE RACK	
137	RMB0268	SPRING, HOLDER HOOK	
138	RMLD271A	HOLDER HOOK	
139	XTW2+6S	SCREW	
140	RXR0018	REEL TABLE	
141	XTW2+5L	SCREW	
142	XTW26+12S	SCREW	
143	XTW26+6L	SCREW	
144	RFKJSCH404AK	SUB CHASSIS ASS'Y	
145	RFKJSCH404BK	CHASSIS ASS'Y	

### MECHANISM PARTS LOCATION

(Top view)

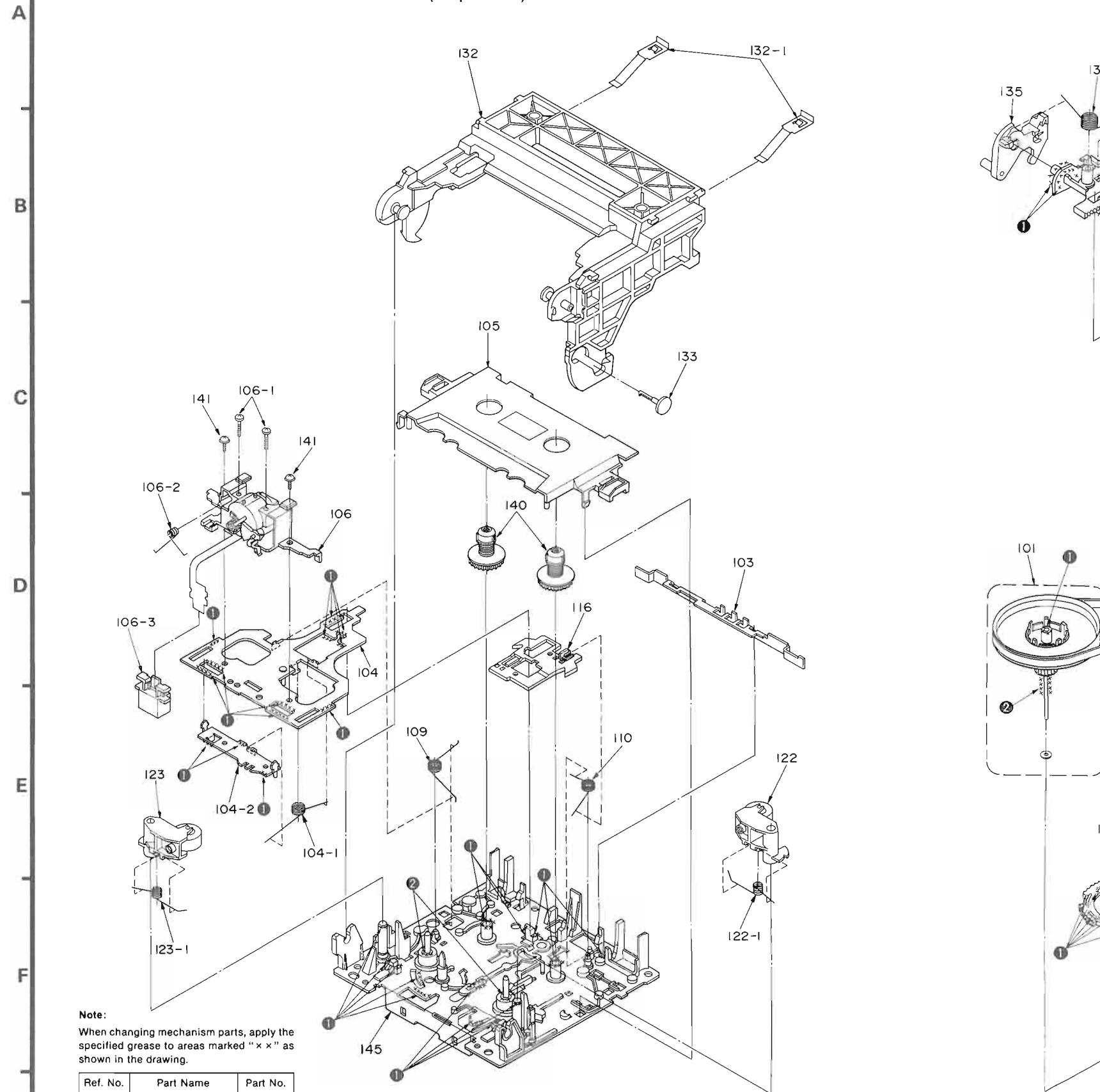



# REPLACEMENT PARTS LIST

**Notes:** \*Important safety notice:

 Components identified by  $\Delta$  mark have special characteristics important for safety.

Furthermore, special parts which have purposes of fire-retardant (resistors), high-quality sound (capacitors), low-noise (resistors), etc. are used.

When replacing any of components, be sure to use only manufacturer's specified parts shown in the parts list.

\*The parenthesized indications in the Remarks columns specify the areas. (Refer to the cover page for area.)

Parts without these indications can be used for all areas.

Ref. No.	Part No.	Part Name & Description	Remarks	Ref. No.	Part No.	Part Name & Description	Remarks
		INTEGRATED CIRCUIT(S)		Q707	DTC114ESTP	TRANSISTOR	(E, EB, EG, GC, GN)
				Q709	ZSC3311AIRTA	TRANSISTOR	(E, EB, EG, GC, GN)
IC1	AN7384N-SG	ELECTRIC VOLUME		Q801	2SA1309AIRTA	TRANSISTOR (DECK1)	
IC2	AN7352S-E2	PLAYBACK AMP		Q802	2SA1309A-R	TRANSISTOR (DECK2)	
IC3	AN7353S-E2	REC EQ AMP (DECK2)		Q803	ZSD1450RTA	TRANSISTOR (DECK1)	
IC151	M62352FPE1	12ch D/A CONVERTER		Q804	ZSD1450RTA	TRANSISTOR (DECK2)	
IC152	XLU2040F-T1	DATA CONTROL				DIODE (S)	
IC301	UPC1297CA	DOLBY HX PRO (DECK2)		D3, 4	MA167	DIODE	
IC302	SV1BA4560FT1	E. CURRENT ADJ. CONT. (DECK2)		D5	MA165	DIODE	
IC401	AN7354SC-E2	DOLBY B/C NR		D6	MTZJ6R2BTA	DIODE	
IC701	M38123M4101F	MICROCOMPUTER		D150, 151	MA165	DIODE	
IC702	XLJ93LC46AFE	EEPROM		D152	MTZJ5R1BTA	DIODE	$\Delta$
IC801	BA6265FP-E1	MECHANISM CONTROL (DECK1)		D154, 155	RL1N4003N02	DIODE	
IC802	BA6265FP-E1	MECHANISM CONTROL (DECK2)		D158, 159	MA165	DIODE	
IC971	RVSGP2S24BC	PHOTO INTERRUPTER (DECK1)		D301, 302	MTZJ6R8BTA	DIODE	
IC971A	RVSGP2S24BC	PHOTO INTERRUPTER (DECK2)		D303-307	MA165	DIODE	
IC972	RVSGP2S24BC	PHOTO INTERRUPTER (DECK1)		D401, 402	MA165	DIODE	
IC972A	RVSGP2S24BC	PHOTO INTERRUPTER (DECK2)		D601, 602	MA165	DIODE	$\Delta$
		TRANSISTOR(S)		D603-610	RL1N4003N02	DIODE	$\Delta$
				D611	MA165	DIODE	
Q3, 4	2SJ164PQRTA	TRANSISTOR		D613	MTZJ8R2CTA	DIODE	$\Delta$
Q5	DTA114ESTP	TRANSISTOR		D614	MTZJ6R2BTA	DIODE	$\Delta$
Q6-8	ZSC3311AIRTA	TRANSISTOR		D615	MTZJ20DTA	DIODE	$\Delta$
Q301	2SA1309AIRTA	TRANSISTOR		D616	MA165	DIODE	
Q302, 303	ZSC3311AIRTA	TRANSISTOR		D701	LN28RPX	L. E. D.	(E, EB, EG, GC, GN)
Q304	KSB564ACYGTA	TRANSISTOR		D801	MA188TA	DIODE (DECK1)	
Q305	KSD471ACYGTA	TRANSISTOR		D802	MA188TA	DIODE (DECK2)	
Q306	ZSB1030AQSTA	TRANSISTOR		D803	MA723TA	DIODE (DECK1)	
Q401-406	ZSC3311AIRTA	TRANSISTOR		D804	MA723TA	DIODE (DECK2)	
Q601, 602	ZSD1450RTA	TRANSISTOR		D971	RVD1SS133TA	DIODE (DECK1)	
Q603	DTC114ESTP	TRANSISTOR		D971A	RVD1SS133TA	DIODE (DECK2)	
Q604	2SA1309AIRTA	TRANSISTOR				VARIABLE RESISTOR(S)	
Q605	ZSD2037EFTA	TRANSISTOR	$\Delta$	VR702	EVJ02FFA7B15	REC LEVEL CONTROL	
Q606	2SA1309AIRTA	TRANSISTOR		VR801	EVNDCAA03B53	TAPE SPEED ADJ. (DECK1:X1)	
Q607	ZSB1357EFTA	TRANSISTOR	$\Delta$	VR802	EVNDCAA03B53	TAPE SPEED ADJ. (DECK2:X2)	
Q608	ZSD2037EFTA	TRANSISTOR	$\Delta$	VR803	EVNDCAA03B53	TAPE SPEED ADJ. (DECK2:X1)	
Q609	KSB564ACYGTA	TRANSISTOR	$\Delta$			COIL(S)	
Q610	ZSB1357EFTA	TRANSISTOR		L1, 2	SLQX303-1KT	COIL	
Q611	ZSD2037EFTA	TRANSISTOR		L301, 302	SL09B1-Z	COIL	
Q612, 613	ZSD2037EFTA	TRANSISTOR	$\Delta$	L303	SL09B4-K	COIL (HX PRO ADJ.)	
Q702	ZSC3311AIRTA	TRANSISTOR		L401, 402	RLM2B006T-K	COIL	
Q703	DTC114YSTP	TRANSISTOR					
Q704	DTC114YSTP	TRANSISTOR	(P, PC)				
Q705	DTC114YSTP	TRANSISTOR					
Q706	DTC114YSTP	TRANSISTOR	(P, PC)				



# RESISTORS AND CAPACITORS

Notes : \* Capacity values are in microfarads (uF) unless specified otherwise, P=Pico-farads (pF) F=Farads (F)  
 \* Resistance values are in ohms, unless specified otherwise, 1K=1,000 (OHM), 1M=1,000k (OHM)

Ref. No.	Part No.	Values & Remarks	Ref. No.	Part No.	Values & Remarks	Ref. No.	Part No.	Values & Remarks
		RESISTORS	R313	ERDS2TJ822	1/4W 8.2K	R762	ERDS2TJ151	1/4W 150 (E, EB, EG, GC, GN)
			R314	ERDS2TJ471	1/4W 470			
			R315	ERDS2TJ561	1/4W 560	R801	ERDS2TJ1R2	1/4W 1.2 (DECK1)
R3, 4	ERDS2TJ224T	1/4W 220K	R316, 317	ERDS2TJ183T	1/4W 18K	R802	ERDS2TJ2R2T	1/4W 2.2 (DECK2)
R5, 6	ERDS2TJ225	1/4W 2.2M	R318	ERDS2TJ393	1/4W 39K	R803	ERDS2TJ153	1/4W 15K (DECK1)
R7, 8	ERDS2TJ224T	1/4W 220K	R319	ERDS2TJ103	1/4W 10K	R804	ERDS2TJ103	1/4W 10K (DECK1)
R10	ERDS2TJ225	1/4W 2.2M	R320	ERDS2TJ332	1/4W 3.3K	R805	ERDS2TJ392T	1/4W 3.9K (DECK1)
R11-14	ERDS2TJ101	1/4W 100	R321	ERDS2TJ102	1/4W 1K	R806	ERDS2TJ123	1/4W 12K (DECK2)
R15, 16	ERDS2EJ121	1/4W 120	R322, 323	ERDS2TJ100	1/4W 10	R807	ERDS2TJ103	1/4W 10K (DECK2)
R17, 18	ERDS2TJ474	1/4W 470K	R324	ERDS2TJ122	1/4W 1.2K	R808	ERDS2TJ392T	1/4W 3.9K (DECK2)
R19, 20	ERDS2TJ103	1/4W 10K	R325	ERD2FCVG270T	1/4W 27 $\Delta$	R811	ERDS2TJ474	1/4W 470K (DECK1)
R21, 22	ERDS2TJ273	1/4W 27K	R327	ERD2FCVG270T	1/4W 27 $\Delta$	R812	ERDS2TJ474	1/4W 470K (DECK2)
R23, 24	ERDS2TJ183T	1/4W 18K	R328	ERDS2TJ222	1/4W 2.2K	R819	ERDS2TJ271	1/4W 270 (DECK1)
R25, 26	ERDS2TJ103	1/4W 10K	R329	ERDS2TJ473	1/4W 47K	R820	ERDS2TJ271	1/4W 270 (DECK2)
R27, 28	ERDS2TJ101	1/4W 100	R330	ERD2FCVG270T	1/4W 27 $\Delta$	R971	ERDS2TJ221	1/4W 220 (DECK1)
R29	ERDS2TJ332	1/4W 3.3K	R332	ERDS2TJ102	1/4W 1K	R971A	ERDS2TJ221	1/4W 220 (DECK2)
R30	ERDS2TJ472	1/4W 4.7K	R334	ERDS2TJ182	1/4W 1.8K	R973	ERDS2TJ393	1/4W 39K (DECK1)
R31, 32	ERDS2TJ103	1/4W 10K	R401-404	ERDS2TJ474	1/4W 470K	R973A	ERDS2TJ393	1/4W 39K (DECK2)
R33, 34	ERDS2TJ823T	1/4W 82K	R405, 406	ERDS2TJ152	1/4W 1.5K	R974	ERDS2TJ393	1/4W 39K (DECK1)
R35	ERDS2TJ124T	1/4W 120K	R407, 408	ERDS2TJ332	1/4W 3.3K	R974A	ERDS2TJ393	1/4W 39K (DECK2)
R36	ERDS2TJ223	1/4W 22K	R409, 410	ERDS2TJ223	1/4W 22K			CAPACITORS
R38	ERDS2TJ102	1/4W 1K	R411, 412	ERDS2TJ473	1/4W 47K			
R41, 42	ERDS2TJ183T	1/4W 18K	R413, 414	ERDS2TJ104	1/4W 100K			
R43, 44	ERDS2TJ393	1/4W 39K	R601-604	ERDS2TJ472	1/4W 4.7K	C3, 4	ECBT1H561KB5	50V 560P
R45, 46	ERDS2TJ394	1/4W 390K	R605	ERDS2TJ1R0	1/4W 1.0	C5, 6	ECBT1H102KB5	50V 1000P
R47, 48	ERDS2TJ561	1/4W 560	R606, 607	ERDS2TJ472	1/4W 4.7K	C7, 8	ECBA1H681KB5	50V 680P
R49, 50	ERDS2TJ222	1/4W 2.2K	R608	ERDS2TJ103	1/4W 10K	C10	ECEA1HKA0R1B	50V 0.1U
R55	ERDS2TJ223	1/4W 22K	R609	ERDS2TJ102	1/4W 1K	C11, 12	ECBT1E103ZF	25V 0.01U
R56	ERDS2TJ332	1/4W 3.3K	R610	ERDS2TJ152	1/4W 1.5K	C13, 14	ECQB1H682JF3	50V 6800P
R59	ERDS2TJ393	1/4W 39K	R611	ERDS2TJ101	1/4W 100	C15, 16	ECEA1AU101	10V 100U
R60	ERDS2TJ333	1/4W 33K	R612	ERDS2TJ562	1/4W 5.6K	C17	ECEA1HKAR47B	50V 0.47U
R61, 62	ERDS2TJ562	1/4W 5.6K	R613	ERDS2TJ682T	1/4W 6.8K	C18	ECEA1CKA100B	16V 10U
R63, 64	ERDS2TJ222	1/4W 2.2K	R614	ERDS2TJ222	1/4W 2.2K	C19, 20	ECKR2H121KB5	500V 120P
R67, 68	ERDS2TJ103	1/4W 10K	R615	ERDS2TJ101	1/4W 100	C21, 22	ECEA1CKA100B	16V 10U
R69, 70	ERDS2TJ682T	1/4W 6.8K	R616	ERDS2TJ222	1/4W 2.2K	C23, 24	ECEA1HKA2R2B	50V 2.2U
R80	ERDS2TJ561	1/4W 560	R617, 618	ERDS2TJ101	1/4W 100	C25, 26	ECEA1HKAR47B	50V 0.47U
R150	ERDS2TJ103	1/4W 10K	R619	ERDS2TJ331	1/4W 330	C27, 28	ECEA1CN100SB	16V 10U
R158	ERDS2TJ223	1/4W 22K	R620, 621	ERDS2TJ101	1/4W 100	C29-32	ECEA1CKA100B	16V 10U
R173	ERDS2TJ221	1/4W 220	R622, 623	ERD2FCVJ6R8T	1/4W 6.8 $\Delta$	C33, 34	ECEA1CKA220B	16V 22U
R174-176	ERDS2TJ103	1/4W 10K	R624-626	ERD2FCVG100T	1/4W 10 $\Delta$	C35	ECKR1H392KB5	50V 3900P
R301, 302	ERDS2TJ153	1/4W 15K	R627	ERD2FCVJ6R8T	1/4W 6.8 $\Delta$	C37	ECEA1HKA010B	50V 1U
R303, 304	ERDS2TJ103	1/4W 10K	R628	ERDS2TJ101	1/4W 100	C39, 40	ECBT1E103ZF	25V 0.01U
R305, 306	ERDS2TJ154	1/4W 150K	R630	ERD2FCVJ6R8T	1/4W 6.8 $\Delta$	C41, 42	ECEA1HKA010B	50V 1U
R307	ERDS2TJ100	1/4W 10	R631, 632	ERD2FCVG270T	1/4W 27 $\Delta$	C43, 44	ECEA1CKA100B	16V 10U
R308	ERDS2TJ1R0	1/4W 1.0	R633	ERD2FCVJ6R8T	1/4W 6.8 $\Delta$	C61, 62	ECBT1H561KB5	50V 560P
R309	ERDS2TJ100	1/4W 10	R634	ERDS2TJ101	1/4W 100	C63	ECEA1CKA100B	16V 10U
R310	ERD2FCVG270T	1/4W 27 $\Delta$	R635	ERDS2TJ561	1/4W 560	C64	ECEA1HKA010B	50V 1U
R311	ERDS2TJ102	1/4W 1K	R699	ERDS2TJ2R7T	1/4W 2.7	C65	ECBT1E103ZF	25V 0.01U
R312	ERDS2TJ682T	1/4W 6.8K	R701, 702	ERDS2TJ331	1/4W 330	C67, 68	ECBT1C472KR5	16V 4700P

Ref. No.	Part No.	Values & Remarks	Ref. No.	Part No.	Values & Remarks			
C151	ECEAJU221	6.3V 220U	C700, 701	ECEA1CKA100B	16V 10U			
C152	ECBT1E103ZF	25V 0.01U	C703, 704	ECEA1CKA100B	16V 10U			
C153	ECA0JM102B	6.3V 1000U	C705	ECEA1EKA4R7B	25V 4.7U			
C154	ECBT1H331KB5	50V 330P	C710	ECEA1HKA010B	50V 1U			
C175	ECBT1H121KB5	50V 120P	C711	ECBT1E103ZF	25V 0.01U			
C301	ECBT1E103ZF	25V 0.01U	C801	ECBT1E223ZF	25V 0.022U (DECK1)			
C302	ECEA1CKA100B	16V 10U	C802	ECBT1E223ZF	25V 0.022U (DECK2)			
C303, 304	ECBT1C122KR5	16V 1200P	C803	ECEA1EKA101Q	25V 100U (DECK1)			
C305, 306	ECQB1H103JF3	50V 0.01U	C804	ECEA1AKA101B	10V 100U (DECK1)			
C307, 308	ECQB1H223JF3	50V 0.022U	C805	ECBT1H104ZF5	50V 0.1U (DECK1)			
C309, 310	ECQV1H473JM3	50V 0.047U	C806	ECBT1H104ZF5	50V 0.1U (DECK2)			
C311, 312	ECBT1H121KB5	50V 120P	C807	ECEA1EKA101Q	25V 100U (DECK2)			
C313, 314	ECKR2H821KB5	500V 820P	C808	ECEA1AKA101B	10V 100U (DECK2)			
C315, 316	ECBT1E223ZF	25V 0.022U	C811, 812	ECBT1H101KB5	50V 100P (DECK1)			
C317	ECBT1H220J5	50V 22P	C813	ECBT1H104ZF5	50V 0.1U (DECK1)			
C318	ECQP1153JZ	100V 0.015U	C814	ECBT1H104ZF5	50V 0.1U (DECK2)			
C320	ECBT1H220J5	50V 22P	C815, 816	ECBT1H101KB5	50V 100P (DECK2)			
C322	ECEA1AU221	10V 220U	C817	ECBT1H101KB5	50V 100P (DECK1)			
C323	ECBT1E103ZF	25V 0.01U	C818	ECBT1H101KB5	50V 100P (DECK2)			
C324	ECEA1EKA4R7B	25V 4.7U	C821	ECEADJKA221B	6.3V 220U (DECK1)			
C325	ECKR1H392KB5	50V 3900P	C822	ECEADJKA221B	6.3V 220U (DECK2)			
C326	ECEA1HKA0R1B	50V 0.1U						
C327	ECKW1H222KB5	50V 2200P						
C328	ECKD1H682KB	50V 6800P						
C329	ECKW1H222KB5	50V 2200P						
C330	ECBT1E103ZF	25V 0.01U						
C332, 333	ECBT1E103ZF	25V 0.01U						
C401, 402	ECBT1C222KR5	16V 2200P						
C403, 404	ECBT1C182KR5	16V 1800P						
C405, 406	ECBT1C222KR5	16V 2200P						
C407, 408	ECQV1H154JM3	50V 0.15U						
C409, 410	ECEA1HKA010B	50V 1U						
C411, 412	ECEA1HKA2R2B	50V 2.2U						
C413, 414	ECEA1HKA010B	50V 1U						
C415, 416	ECQB1H152JF3	50V 1500P						
C417, 418	ECEA1HKAR47B	50V 0.47U						
C419, 420	ECQB1H152JF3	50V 1500P						
C421, 422	ECEA1HKAR47B	50V 0.47U						
C423, 424	ECBT1H820KB5	50V 82P						
C425, 426	ECBT1C682KR5	16V 6800P						
C601	ECEA1EU222B	25V 2200U $\Delta$						
C602	ECA1EM221B	25V 220U						
C603, 604	ECA1EM102B	25V 1000U $\Delta$						
C605	ECKR2H682PE	500V 6800P						
C606	ECBT1E103ZF	25V 0.01U						
C607	ECEA1AU221	10V 220U						
C608-614	ECBT1E103ZF	25V 0.01U						
C615	ECEA1CKA100B	16V 10U						
C616, 617	ECA1AM102B	10V 1000U						
C618	ECA1EM221B	50V 220U $\Delta$						
C619	ECBT1E103ZF	25V 0.01U						
C630	ECBT1E103ZF	25V 0.01U						